

Full HD Camera Module

MP3010M-EV

Technical Reference Manual

Ver. 1.00

The contents of this manual are subject to change without prior notice.

TAMRON assume no responsibility for any disadvantage or damage caused by such changes.

REVISION HISTORY

Ver. 1.00 2022/08/19 First Edition Release

TABLE OF CONTENTS

1. Features	6
2. Precautions	7
3. Basic Functions	10
3.1 VISCA Commands.....	10
Timing Chart.....	10
Turn On a MP3010M-EV (from no power supplied)	10
3.2 Zoom.....	11
3.3 Focus.....	12
3.4 Image Stabilizer	15
3.5 White Balance	16
3.6 AE (Automatic Exposure)	17
AE - Full auto	17
AE - Shutter priority	18
AE - Iris priority	19
AE - Manual	20
3.7 Spot Exposure	21
3.8 Exposure Compensation.....	22
3.9 AE Response	23
3.10 Long Exposure (Slow Shutter).....	23
3.11 Slow Shutter Limit.....	24
3.12 Gain Limit Setting	24
3.13 Aperture Control.....	24
3.14 Back Light Compensation.....	25
3.15 Wide Dynamic Range Mode (WDR)	25
3.16 Defog	26
3.17 Noise Reduction	26
3.18 3D Noise Reduction.....	26
3.19 Gamma	27

3.20 Low-Illumination Chroma Suppress	27
3.21 Temperature Reading Function.....	27
3.22 ICR (IR Cut-Removable) Mode.....	28
3.23 Auto ICR Mode	28
3.24 Color Gain	29
3.25 Color Hue	29
3.26 Effect.....	29
3.27 E-flip and Mirror	30
3.28 Freeze.....	30
3.29 Memory	30
3.30 Register setting	32
3.31 Title Display	35
Title Display Setting Command List	35
3.32 Privacy Zone Masking Function	37
Features.....	37
Privacy Zone Mask Command List	37
Privacy Zone Mask Inquiry Command List	38
How to use Each Command.....	38
3.33 Keystone Correction	43
3.34 Lens Distortion Correction	44
3.35 Zoom Position Limit.....	45
3.36 Initial Settings, Custom Presets	46
4. VISCA Commands.....	48
4.1 VISCA/RS-232C Commands.....	48
4.2 Overview of VISCA	48
4.3 VISCA Communication Specifications	49
VISCA Packet Structure	49
Commands and Inquiries.....	50
Responses for commands and inquiries.....	50
Socket Number	51

Command Execution Cancel.....	52
4.4 VISCA Device Setting Commands.....	52
For VISCA Network Administration	52
VISCA Interface Commands.....	53
VISCA Interface and Inquiry	53
4.5 VISCA Commands/ACK Protocol.....	54
4.6 VISCA Camera-Issued Messages	54
ACK/Completion Messages.....	54
Error Messages.....	55
Network Change Message	55
4.7 VISCA Command List.....	56
4.8 VISCA Command Setting Values.....	59
5. Specification.....	62
5.1 Specification.....	62
5.2 Dimension and Eclipse.....	63
5.3 Interface	64
5.3.1 LVDS Interface Overview	64
5.3.2 LVDS Pin Assignment	65
5.3.3 LVDS Pixel Data Format.....	66
5.3.4 LVDS Rx Circuit Example.....	68
5.3.5 LVDS cable specification (reference)	74
5.3.6 Synchronization Code	75
5.4 USB Interface	76
5.4.1 USB Interface Overview.....	76
5.4.2 USB Pin Assignment.....	77
5.5 HDMI Interface	78
5.5.1 HDMI Interface Overview	78
5.5.2 HDMI Pin Assignment	79

1. Features

1. Small size and Light Weight High Resolution Camera

- Overall length is 59mm. Weight is about 70g. It achieved small size and light weight.
- Because of the small size and light weight, it enables to use existing housing and reduce space.

2. Full HD High Quality Camera

- It supports 1920 x 1080 full HD video output.
- It is available by various uses.

3. High Optics Performance

- It realizes color blur reduction and high contrast by putting TAMRON's original optics design and low reflection coating technologies together.

2. Precautions

Software

Use of demonstration software developed by TAMRON or use of the software with customer developed application software may damage hardware, the application program or the camera module. TAMRON is not liable for any damages under these conditions.

Operation and storage conditions

Do not shoot images that are extremely bright (e.g., light sources, the sun, etc.) for long periods of time. Do not use or store the camera module in the following extreme conditions:

- Extremely hot or cold places (operating temperature $-5\text{ }^{\circ}\text{C}$ to $+60\text{ }^{\circ}\text{C}$ ($23\text{ }^{\circ}\text{F}$ to $140\text{ }^{\circ}\text{F}$))
- Close to generators of powerful electromagnetic radiation such as radio or TV transmitters
- Where it is subject to fluorescent light reflections
- Where it is subject to unstable (flickering, etc.) lighting conditions
- Where it is subject to strong vibration
- Where it is subject to radiation from laser beams

Care of the unit

Remove dust or dirt on the surface of the lens with a commercially available blower.

Others

Please warn the top surface and a lateral board on the occasion of this plane handling not to take excessive load. Disconnection may occur by the transformation of the board inside and causes the trouble.

Please do not take excessive load on the sensor board which a back part has. The sensor board is installed on a lens after adjustment precisely. When load increases, influence may leave an optical axis gap, the sided blur, etc. in optics performance.

In addition, an electric circuit may be injured by static electricity (ESD) (electrostatic destruction). When handling this module, please discharge static electricity (e.g., touch the grounded metal) in order to prevent electrostatic destruction.

Do not apply excessive voltage. Use only the specified voltage. Otherwise, you may get an electric shock or a fire may occur.

In case of abnormal operation, contact your authorized TAMRON dealer or the store where you purchased the product.

Phenomena specific to CMOS image sensors

The following phenomena that may appear in images are specific to CMOS (Complementary Metal-Oxide Semiconductor) image sensors. They do not indicate malfunctions.

Rolling shutter skew

As CMOS image sensors use shutters that capture images line-by-line, there is a slight time difference between the top and bottom of an image. As a result, images may appear skewed if the camera module is moved.

White flecks

Although the CMOS image sensors are produced with high-precision technologies, fine white flecks may be generated on the screen in rare cases, caused by cosmic rays, etc. This is related to the principle of CMOS image sensors and is not a malfunction.

The white flecks especially tend to be seen in the following cases ;

- When operating at a high environmental temperature
- When you have raised the master gain (sensitivity)
- When operating in Slow-Shutter mode

Aliasing

When fine patterns, stripes, or lines are shot, they may appear jagged or flicker.

Phenomena Specific to Lenses

Ghosting

If a strong light source (e.g., the sun) exists near the incidence angle of the lens, bright spots may appear in the image due to diffuse reflection within the lens.

Output Format

This module can output 1080p 60fps, 59.59fps and 50fps, 148.5MHz digital output. A receiver must be designed to support the frequency.

Generation of heat

Do not operate the zoom continuously for more than 5 minutes, as the power consumption increases during motor control. The generation of heat may cause a malfunction.

For continuous zoom operation, allow enough time intervals between operations.

Also, please pay attention to the enclosure design because there is a risk of burns from touching hot components or low-temperature burns from prolonged contact with the human body.

Backside Seal

Do not remove the black seal on the rear of the main unit. It may affect the performance of the product.

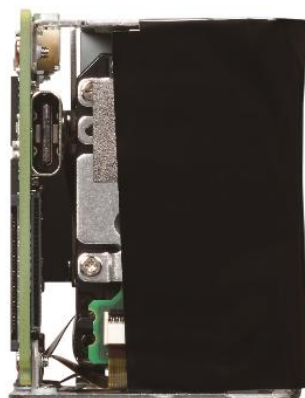

Rear view

3. Basic Functions

3.1 VISCA Commands

Camera control is performed by VISCA Commands.

Timing Chart

As VISCA Command processing can only be carried out one time in a Vertical cycle, it takes the maximum 1V cycle time for an ACK/Completion to be returned. If the Command ACK/Completion communication time is shorter than the 1V cycle time, then every 1V cycle can receive a Command.

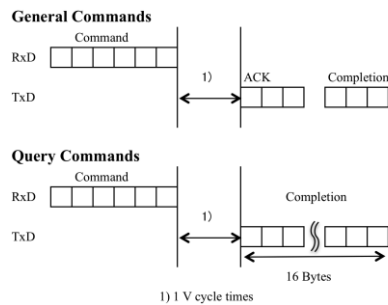

VISCA commands are described in detail at Chapter 4 Command List.

Turn On a MP3010M-EV (from no power supplied)

When MP3010M-EV is turned on from no power supplied, MP3010M-EV transmits a "Network Change" command through Tx. Because of "From No Power Supplied", there might be invalid data transmitted before the "Network Change" command at the time. One terminator "FF" is added just before the "Network Change" command, so the terminator "FF" and other previous data and packets can be detected and must be ignored.

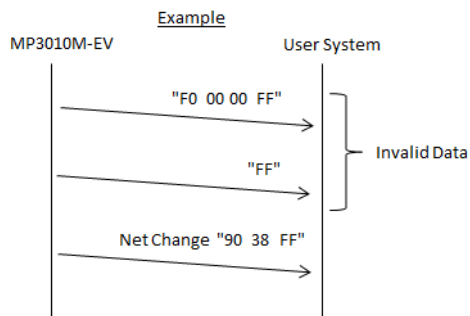

3.2 Zoom

The camera module employs a 10x optical zoom and supports 16x digital zoom.

- **Lens Specification**

F value: 3.3 mm to 33.0 mm (F1.8 to F3.4)

Horizontal view of angle: 59.2 degree (wide end) to 6.7 degree (tele end)

The following are zoom modes. A VISCA Command (CAM_Zoom Command) controls the modes.

Standard Speed Mode

Zoom moves at fixed speed.

Variable Speed Mode

There are eight levels of zoom speed that can be set by a VISCA Command.

In these standard speed mode and variable speed mode, send Stop Command to stop the zoom operation.

Digital Zoom On/Off

After the Optical Zoom has reached its maximum level (10x), the camera switches to Digital Zoom Mode.

Direct Zoom Position setting

Setting the zoom position enables quick movement to the designated position.

Continues Zoom position Reply

With ZoomDirect mode, or when zooming according to a preset, the camera outputs zoom position data when Continues Zoom position Reply is set to On via a VISCA Command (CAM_ContinuousZoomReply Command).

Users can set the Interval Time using CAM_ReplyIntervalTimeSet Command.

3.3 Focus

Focus has the following modes, all of which can be set using VISCA Commands (CAM_Focus Command).

- **Auto Focus Mode**

The Auto Focus (AF) function automatically adjusts the focus position to strong contrast subject in the AF Frame. The minimum focus distance is 10mm at the optical wide end and 800 mm at the optical tele end. The default minimum focus distance is 250mm.

- **Normal AF Mode**

This is the normal mode so that AF operations are always active.

- **Interval AF Mode**

The mode used for AF movements carried out at particular intervals. The time intervals for AF movements and for the timing of the stops can be set in one-second increments using the Set Time Command. The initial value for both is set to five seconds.

- **Zoom Trigger Mode**

When the zoom is changed, AF starts after stopping zoom within pre-set value (initially set at 5 seconds). After the pre-set value, even target moves, focus operation is terminated.

- **AF sensitivity**

AF sensitivity can be set to Normal or Low with AF Sensitivity Command.

- **Normal**

The follow-up ability to the change of subject becomes sensitive. Please use this mode to photograph a subject with much movement. This mode is usually most suitable.

- **Low**

The stability of the focus improves. When the illumination is low, AF does not start, even though brightness changes to some extent, and a stable image outputs.

- **Manual Focus Mode**

Manual Focus has two modes, a Standard Speed Mode and a Variable Speed Mode. Standard Speed Mode focuses at a fixed speed. Variable Speed Mode has eight speed levels that can be set using a VISCA Command.

In these Standard and Variable Speed Modes, it is necessary to send Stop Command to stop the focus lens movement.

- **Direct Focus Position**

The focus position can be set by using Direct Command in CAM_Focus CommandSet.

- **Direct Zoom Focus Position**

Both of Zoom Position and Focus Position can be set at a time by using CAM_Zoom Focus Command.

- **One Push Trigger Mode**

When a One Push Trigger Command is sent, whole area scan is executed so that a subject is focused. The focus lens then holds that position until the next One Push Trigger Command or focus movement command (Standard Speed/Variable Speed) is received.

Two types of One Push Trigger modes are available.

- **Mode 1:** Execute whole focus range (Near-Inf) scan. At AF mode, after scan, AF operation continues.

- **Mode 2:** Scan by wobbling, execute only at MF mode.

- **Near Limit Setting**

It can be set in a range from 1000h (∞) to B000h (1.0 cm). Default setting is 8000h (25 cm)

● AF Frame Setting

Using Focus detecting area selection in VISCA register setting command can set to focus on a specific area.

This function is used when it is difficult for the normal autofocus to focus on the desired subject.

The AF Frame area to be focused on is specified by dividing the entire screen into 7 (vertical) x 7 (horizontal) areas.

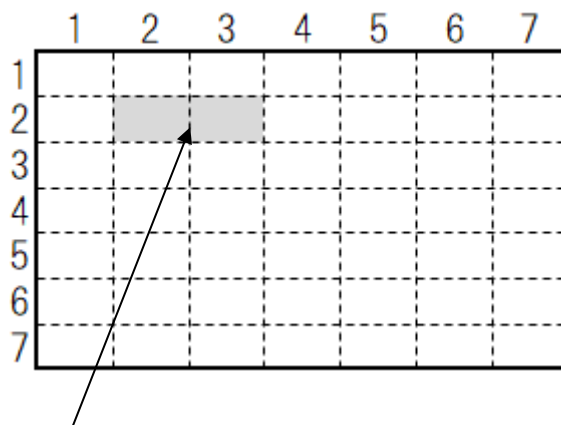

When setting this area, be sure to specify diagonal positions, such as start point (2,2) and end point (3,2).
The default setting is (3,3)(5,5).

● Focus Stop Position Setting

The register setting "Focus stop position" allows you to set the stop position when the AF cannot find the focus position.

At slow speed mode (shutter time is longer than frame period) MP3010M-EV enters long exposure mode so that the follow-up ability will be lower.

3.4 Image Stabilizer

Switching On the Image Stabilizer function reduces image blurring caused by, for example, vibration, which allows you to obtain images without much blurring.

A correction effect is possible for a vibration frequency of around 10Hz. The Image Stabilizer function employs the digital zoom system, so the angle of view and resolution are changed, but the sensitivity is maintained.

Hold Function of Image Stabilizer

With the Image Stabilizer function, suddenly stopping high-speed movement (pan, tilt, etc.) of the camera produces a blur sensor counteraction that may cause image movement. In such a case, you can use a command setting (hold) to maintain the correction of the Image Stabilizer function. In this case the image stabilizer is off, but there is no change in the angle of view.

Note:

The handshake correction function may not work correctly under the condition that high-frequency vibration component exists. In such a case, set the image stabilizer function to Off.

3.5 White Balance

White Balance has the following modes, all of which can be set by using VISCA Command (CAM_WB Command).

- **Auto White Balance (AWB)**

AWB has two modes, ATW1 (Narrow) and ATW2 (Wide).

- **ATW1 (Narrow)**

This covers about 7000K to 2500K color temperature.

ATW1 is factory default setting.

- **ATW2 (Wide)**

This covers about 10000K to 2200K color temperature.

- **Manual WB**

R gain (CAM_RGain Command) 256 steps and B gain (CAM_BGain command) 256 steps can be set manually.

- **Fixed Color Temperature mode**

Two fixed color temperature modes:

- **INDOOR**

Fixed color temperature for indoor use. (about 3200K)

- **OUTDOOR**

Fixed color temperature for outdoor use. (about 5800K)

- **One Push Trigger**

After having taken the image of white paper throughout a screen, please issue One Push Trigger Command in CAM_WB Command. White balance is calculated and shifts to One Push WB mode.

- **One Push WB**

The One Push White Balance mode is a function to photograph a subject with a fixed white balance mode that use generated WB data by the latest One Push Trigger.

3.6 AE (Automatic Exposure)

AE has the following 4 modes, all of which can be set using VISCA Command (CAM_AE Command). A variety of AE functions are available for optimal output of subjects in lighting conditions that range from low to high.

- Full Auto
- Shutter Priority
- Iris Priority
- Manual

The motion in each mode is as follows.

	Iris	Shutter	Gain
Full Auto	Auto	Auto	Auto
Shutter Priority	Auto	Fix	Auto
Iris Priority	Fix	Auto	Auto
Manual	Fix	Fix	Fix

AE - Full auto

This mode can be set using Full Auto Command.

Controlling automatically Iris, Gain, and Shutter Speed.

In this mode, users can select Flicker Auto Detect On in which camera module automatically detects electricity frequency and adjusts the shutter speed in order to eliminate flickering (or so called banding) and Flicker Auto Detect Off in which camera module does not detect.

Setting On/Off uses On/Off Command in CAM_FlickerAutoDetect Command. The default setting is Off.

AE - Shutter priority

This mode can be set using Shutter Priority Command.

The shutter speed can be set one out of 22 steps. Iris and Gain are automatically adjusted.

Users can set a Shutter Speed with auto Iris and Gain. (1/1 to 1/10,000 sec., 16 high-speed shutter speeds plus 6 low-speed shutter speeds)

Flicker can be eliminated by setting shutter speed to ;

- 1/100 in countries with a 50 Hz power supply frequency
- 1/120 in countries with a 60 Hz power supply frequency

Shutter Speed Setting:

Data	60/30 mode	50/25 mode
15h	1/10000	1/10000
14h	1/6000	1/6000
13h	1/4000	1/4000
12h	1/3000	1/3000
11h	1/2000	1/2000
10h	1/1500	1/1500
0Fh	1/1000	1/1000
0Eh	1/725	1/725
0Dh	1/500	1/500
0Ch	1/350	1/350
0Bh	1/250	1/250

Data	60/30 mode	50/25 mode
0Ah	1/180	1/180
09h	1/120	1/120
08h	1/100	1/100
07h	1/90	1/75
06h	1/60	1/50
05h	1/30	1/25
04h	1/15	1/12
03h	1/8	1/6
02h	1/4	1/3
01h	1/2	1/2
00h	1/1	1/1

Data can be set using Direct Command in CAM_Shutter Command.

AE - Iris priority

This mode can be set using Iris Priority Command.

The iris can be set one in 16 steps between F1.8 and Close. The gain and shutter speed are set automatically.

Iris Setting:

Data	Setting
11h	F1.8
10h	F2
0Fh	F2.4
0Eh	F2.8
0Dh	F3.4
0Ch	F4
0Bh	F4.8
0Ah	F5.6

Data	Setting
09h	F6.8
08h	F8
07h	F9.6
06h	F11
05h	F14
04h	F16
03h	F22
00h	CLOSE

Data can be set using Direct Command in CAM_Iris Command.

AE - Manual

This mode can be set using Manual Command.

The shutter speed (22 steps), iris (16 steps) and gain (28 steps) can be set individually.

Gain Setting:

Data	Setting
1Ch	+54 dB
1Bh	+52 dB
1Ah	+50 dB
19h	+48 dB
18h	+46 dB
17h	+44 dB
16h	+42 dB
15h	+40 dB
14h	+38 dB
13h	+36 dB
12h	+34 dB
11h	+32 dB
10h	+30 dB
0Fh	+28 dB
0Eh	+26 dB

Data	Setting
0Dh	+24 dB
0Ch	+22 dB
0Bh	+20 dB
0Ah	+18 dB
09h	+16 dB
08h	+14 dB
07h	+12 dB
06h	+10 dB
05h	+8 dB
04h	+6 dB
03h	+4 dB
02h	+2 dB
01h	0 dB
00h	0 dB

Data can be set using Direct Command in CAM_Gain CommandSet.

At the same time, set Iris Data and Shutter Data together.

3.7 Spot Exposure

In each exposure mode except Manual mode, the level for the entire screen is calculated, and the optimum Iris, Gain and Shutter levels are determined. In Spot Exposure, a particular section of the subject can be designated, and then that portion of the image is weighted and the value calculated so that Iris, Gain and Shutter are optimized to obtain the entire screen image.

This mode can be set using On/Off Command in CAM_Spot AE Command.

For example, in an image with frequent changes of brightness by a lot of movement, portions without much change can be designated as such a “spot,” and changes to the screen can be minimized.

As shown in the diagram below, a spot block in a range of 16 blocks vertically and 16 blocks horizontally can be designated. In the case where the center block is designated (shown in yellow), the level is calculated along with a weighted value for the surrounding blocks (blue) and the specified center (yellow) block, and then the Iris, Gain and Shutter are set. The weight of the center (yellow) block is 100% and the weight of surrounding blocks (blue) is 20%. The range of the Spot AE frame is fixed to 3 blocks vertically and 3 blocks horizontally.

Since Spot Exposure and Back Light Compensation cannot be set at the same time, please use it after setting Back Light Compensation to Off.

	0	1	2	3	4	5	6	7	8	9	10	11	12	13	14	15
0																
1			■	■	■											
2			■	■	■											
3			■	■	■											
4																
5																
6																
7																
8																
9																
10																
11																
12																
13																
14																
15																

- Spot photometry: center area
- Spot photometry: surrounding area

The above coordinate is selected by Position Command of CAM_Spot AE Command.

It is an example which is set using 8X 01 04 29 00 03 00 02 FF command when the coordinate is x=3, y=2.

3.8 Exposure Compensation

Exposure compensation adjusts brightness in the AE mode. Normal brightness is 0. The adjusted brightness can be brighter or darker by 2 dB/Step.

Exposure compensation Setting:

Data	Step	Setting
0Dh	+6	+12 dB
0Ch	+5	+10 dB
0Bh	+4	+8 dB
0Ah	+3	+6 dB
09h	+2	+4 dB
08h	+1	+2 dB
07h	0	0 dB
06h	-1	-2 dB
05h	-2	-4 dB
04h	-3	-6 dB
03h	-4	-8 dB
02h	-5	-10 dB
01h	-6	-12 dB

Data can be set using Direct Command in CAM_ExpComp Command, and is activated by On Command.

3.9 AE Response

AE Response (convergence speed) function controls the exposure response speed. Using the AE response function sets the automatic exposure response speed from the fastest speed (01h) to the slowest speed (30h).

For example, with the fastest setting, if the headlights of a car are caught by the camera, the camera automatically adjusts the exposure so that it can shoot a high-intensity subject (in this case, the headlights). As a result, images around the headlights, that is, the rest of the subject, except the headlights, becomes relatively dark, and poorly distinguished. However, if the AE response speed is slower, as a result, even if the camera catches a high-intensity subject (e.g., the headlights) for a moment, the image surrounding the headlights can still easily be distinguished.

Data can be set using Direct Command in CAM_AE_Response Command.

3.10 Long Exposure (Slow Shutter)

In very dark environment, the long exposure (VISCA : CAM_SlowShutter Auto/Manual) can get more bright image.

Using VISCA Command (Auto/Manual Command in CAM_SlowShutter CommandSet) can set Slow Shutter mode. At Auto mode it automatically gets into slow shutter at AE Full Auto mode and Iris priority mode. In Manual mode, it won't become slow shutter automatically. It becomes slow shutter by setting shutter speed at Shutter Priority mode and Manual Mode. Factory default is Manual.

3.11 Slow Shutter Limit

It limits the longest shutter time when slow shutter auto mode is active.

It uses Register Setting command and parameters are the following ;

CAM_Register Value command :

Addr = 0x7C

Val = 0 : 1/4 sec (default)

1 : 1/1 sec

2 : 1/2 sec

3 : 1/3 sec

4 : 1/4 sec

5 : 1/6 sec

6 : 1/8 sec

7 : 1/12.5 sec(25/50 fps mode) or 1/15 sec (30/60 fps mode)

3.12 Gain Limit Setting

The gain limit can be set at the Full Auto, Shutter Priority, Iris Priority mode.

Use this setting when image signal-to-noise ratio is particularly important. MP3010M-EV has max. 54 dB gain. If you limit the gain by Gain Limit to lower gain like 28 dB, you will get better signal-to-noise ratio.

3.13 Aperture Control

When shooting text, this control may help to increase readability by making them sharper. There are 16 steps of adjustment. The factory default is level 8.

Level 0 is edge enhancement off. Data can be set using Direct Command or Up/Down command in CAM_Aperture Command.

3.14 Back Light Compensation

When the background of the subject is too bright and the subject is too dark due to AE, back light compensation will make the subject appear clearer.

Since this cannot be used together with spot exposure, spot exposure must be Off beforehand.

This can be set using BackLight Comp On Command in CAM_LightAdjust Command.

3.15 Wide Dynamic Range Mode (WDR)

The Wide Dynamic Range mode is a function to compensate image with blocked-up shadows and blown-out highlights in accordance with the intensity difference. It enables you to obtain images from dark part to bright part can be recognized, even when capturing a subject with a large intensity difference that is backlight or includes extremely bright portions.

This mode is set using WD On/Off Command in CAM_WD Command.



WDR Off



WDR On

Note:

MP3010M-EV WDR does not reduce frame rate. For example, if MP3010M-EV is set to 1080p 60 frames per second and turn WDR on, it still keeps 60 frames per second output.

3.16 Defog

This function is set using Defog Command.

Defog function is to get better subject recognition at fog environment.



Defog Off



Defog On

3.17 Noise Reduction

The NR (Noise Reduction) function removes noise (random noise, etc.) to provide clearer images. This function is set using CAM_NR Command.

This function has six steps: levels 1 to 5, plus off (0).

The NR effect is applied in proportion to the gain. In bright subjects, the NR effect difference between levels will become smaller.

3.18 3D Noise Reduction

The 3DNR (3D Noise Reduction) function removes noise (random noise, etc.) to provide clearer images with focusing on temporal changes of noise. This function is set using CAM_NR Command.

This function has six steps: levels 1 to 5, plus off (0). It should be aware that higher level increases afterimage phenomenon against moving subjects.

3.19 Gamma

Gamma correction can be changed using CAM_Gamma Command.

The following four options are available.

00: Standard: for normal use

01: Straight: liner conversion

02: Low Noise (Narrow Range): Narrower dynamic range than standard to reduce noise

03: Wide Range: Wider dynamic range than standard

3.20 Low-Illumination Chroma Suppress

This can configure a chroma suppress mode for low-illumination conditions. This can be useful when color noise is particularly noticeable in such conditions.

This uses CAM_ChromaSuppress Command.

Four levels (Off and 1-3 levels) are available for the low-illumination chroma suppress mode. Higher setting value produces stronger chroma suppressing effect. As it becomes low-illumination more, chroma suppress effect becomes stronger.

3.21 TEMPERATURE READING FUNCTION

The conversion value (hex) of the temperature sensor built in the camera can be read by using an Inquiry command. To read temperature uses CAM_TempInq Command.

The conversion value has some error range, and because the temperature sensor is inside of the camera, this value is not the ambient temperature round the camera. Use it as a reference value.

3.22 ICR (IR Cut-Removable) Mode

An infrared (IR) Cut-Filter can be disengaged from the image path for increased sensitivity in low light environments. The ICR will automatically engage depending on the ambient light, allowing the camera to be effective in day/night environments.

When the auto ICR mode is set to On, the image becomes black and white.

3.23 Auto ICR Mode

Auto ICR Mode automatically switches the settings needed for attaching or removing the IR Cut Filter.

With a set level of darkness, the IR Cut Filter is automatically disabled (ICR On), and the infrared sensitivity is increased.

With a set level of brightness, the IR Cut Filter is automatically enabled (ICR Off).

The setting of ICR On -> Off (Threshold) can be set when Auto ICR is on.

The setting range is 0 dB (00h) to 54 dB (1Ch).

The conditions for determining whether to enable or disable are as follows.

(When AutoICRAAlarmReply is Off)

- ICR Off -> On: When the gain remains at the maximum value (Gain Limit value) for 5 seconds.
- ICR On -> Off: When the gain remains below “maximum value - threshold value” for 5 seconds

AutoICR is exclusive with AE Manual. AE Manual cannot be set when AutoICR is on, and AutoICR cannot be set on in AE Manual.

3.24 Color Gain

This can change color gain (color strength).

This uses Direct Command in CAM_ColorGain Command.

The initial setting 100% (4h) can be set to range from approx. 60% (0h) to 200% (Eh) with 15 stages.

3.25 Color Hue

This can change the color hue (color phase).

This uses Direct Command in CAM_Color Hue Command.

The initial setting 0 degrees (7h) is adjustable between approx. -14 degrees (0h) and +14 degrees (Eh), in 15 increments.

3.26 Effect

This uses Commands in CAM_PictureEffect Command.

It consists of the following functions.

- Off
- Black & White: Monochrome Image

3.27 E-flip and Mirror

This uses Commands in CAM_PictureFlip Command and CAM_LR_Reverse Command.

E-flip

This function reverses the video output from the camera vertically and horizontally.

Mirror

This function reverses the video output from the camera horizontally.

3.28 Freeze

This function captures one frame from the video stream and continuously output the captured one frame.

CAM_FREEZE Command controls On/Off. At power on, it is always Off.

3.29 Memory

Memory (Position preset)

Using the position preset function, 4 sets (0 to 3) of camera shooting conditions can be stored and recalled.

This uses Commands in CAM_Memory Command.

Reset

Clear the designated memory.

Set

Save the data to the designated memory.

Recall

Read the data from designated memory.

The following items are saved in the memory.

- Zoom Position
- Digital Zoom On/Off
- Focus Auto/Manual
- Focus Position
- AE Mode
- Flicker Auto Detect On/Off
- Shutter control parameters
- Iris control parameters
- Gain control parameters
- Exposure Compensation On/Off
- Exposure Level
- Backlight Compensation On/Off
- Slow Shutter On/Off
- AE Response
- White Balance Mode
- R/B Gain
- OnePushWB data
- Aperture Level
- ICR On/Off
- Defog On/Off
- WD On/Off
- Gamma
- AutoICR On/Off
- AutoICRArmReply On/Off

Note:

Too much frequent memory writes may cause memory corruption. It is not recommended to create too much frequent memory writes such as writing data every time when setting is changed.

3.30 Register setting

This uses CAM_RegisterValue Command.

The register setting command can set and change the camera default setting.

Register Setting Command (CAM_RegisterValue Command):

8x 01 04 24 mm 0p 0q FF

mm: Register No. (=00h to 7Fh)

pq: Register Value (=00h to FFh)

Register Inquiry Command (CAM_RegisterValueInq Command):

8x 09 04 24 mm FF

mm: Register No.

y0 50 0p 0p FF

pp: Register Value (returned from the camera)

Example: To set communication speed to 38400 bps

8x 01 04 24 00 00 02 FF

After sending this command, turn power off and back on (power reset) to resume communication control at 38400 bps.

Note:

For the timing to reflect the changes made to the register settings, refer to the Setting value reflection timing in "Register Settings" on the next page.

Register Setting

Register Name	Register No.	Setting value		Reflecting timing
VISCA Baud Rate	00h	00h(default)	9600 bps	Reflected after camera reset
		01h	19200 bps	
		02h	38400 bps	
		03h	115200 bps	
Focus detecting area	20h	Start pos=(x1, y1), End pos=(x2, y2)		Immediate reflection
Focus stop position	21h	10h=Over inf,...,B0h=1.0cm		Immediate reflection
Opt zoom limit(W-end)	50h	00h(default)	No limit	Reflected after camera reset
		EFh	Max value	
Opt zoom limit(T-end)	51h	00h(default)	No limit	Reflected after camera reset
		EFh	Max value	
D-Zoom Max	52h	00h	x1	Immediate reflection
		C0h	x4	
		EAh(Default)	x12	
		F0h	x16	
Zoom Tracking AF	54h	00h	Off	Reflected after camera reset
		01h(default)	On	
Keystone Correction	60h	00h=Off(default), 01h=correction low, ..., 12h=correction high		Immediate reflection
Monitoring Mode	72h	01h(default)	LVDS 1080/30p	Reflected after camera reset
		02h	LVDS 1080/25p	
		05h	LVDS 720/60p	
		06h	LVDS 720/50p	
		07h	LVDS 1080/60p	
		08h	LVDS 1080/50p	
		09h	LVDS 720/59.94p	
		0Bh	CVBS NTSC	
		0Dh	CVBS PAL	
		0Eh	LVDS 720/29.97p	
		0Fh	LVDS 720/30p	
		11h	LVDS 720/25p	
		13h	LVDS 1080/59.94p	
		14h	LVDS 1080/29.97p	
		1Bh	CVBS NTSC(Side cut)	
		1Dh	CVBS PAL(Side cut)	
		30h	HDMI 1080/30p	
		31h	HDMI 1080/25p	
		32h	HDMI 720/60p	
		33h	HDMI 720/50p	
		34h	HDMI 1080/60p	
		35h	HDMI 1080/50p	
		36h	HDMI 720/59.94p	
		39h	HDMI 720/29.97p	
		3Ah	HDMI 720/30p	
		3Bh	HDMI 720/25p	
		3Ch	HDMI 1080/59.94p	
		3Dh	HDMI 1080/29.97p	
		40h	LVDS 1080/30p + CVBS NTSC(Side cut)	
		41h	LVDS 1080/25p + CVBS PAL(Side cut)	
42h	LVDS 720/60p + CVBS NTSC(Side cut)			
43h	LVDS 720/50p + CVBS PAL(Side cut)			
44h	LVDS 1080/60p + CVBS NTSC(Side cut)			
45h	LVDS 1080/50p + CVBS PAL(Side cut)			
46h	LVDS 720/59.94p + CVBS NTSC(Side cut)			
47h	LVDS 1080/30p + CVBS NTSC			

		48h	LVDS 1080/25p + CVBS PAL	
		49h	LVDS 720/29.97p + CVBS NTSC(Side cut)	
		4Ah	LVDS 720/30p + CVBS NTSC(Side cut)	
		4Bh	LVDS 720/25p + CVBS PAL(Side cut)	
		4Ch	LVDS 1080/59.94p + CVBS NTSC(Side cut)	
		4Dh	LVDS 1080/29.97p + CVBS PAL(Side cut)	
		50h	LVDS+HDMI 1080/30p	
		51h	LVDS+HDMI 1080/25p	
		52h	LVDS+HDMI 720/60p	
		53h	LVDS+HDMI 720/50p	
		54h	LVDS+HDMI 1080/60p	
		55h	LVDS+HDMI 1080/50p	
		56h	LVDS+HDMI 720/59.94p	
		59h	LVDS+HDMI 720/29.97p	
		5Ah	LVDS+HDMI 720/30p	
		5Bh	LVDS+HDMI 720/25p	
		5Ch	LVDS+HDMI 1080/59.94p	
		5Dh	LVDS+HDMI 1080/29.97p	
LVDS mode	74h	00h(default) 01h	Single Double	Reflected after camera reset
Lens Distortion Compensation	78h	Upper 4bit Lower 4bit	0h: Crop, 1h: Complete 0h: Off, 1h-4h: Table No.1-4 default: 2h	Immediate reflection
Maximum F number	79h	03h 04h 05h 06h(default) 07h 08h	F22 F16 F14 F11 F9.6 F8.0	Immediate reflection
F Number for Small Aperture Elimination	7Ah	09h: F6.8, 0Ah: F5.6, 0Bh: F4.8, 0Ch: F4.0(default), 0Dh: F3.4, 0Eh: F2.8, 0Fh: F2.4, 10h: F2.0, 11h: F1.8		Immediate reflection
Minimum Shutter Speed	7Bh	0Bh: 1/250, 0Ch: 1/350, 0Dh: 1/500, 0Eh: 1/725, 0Fh: 1/1000, 10h: 1/1500, 11h: 1/2000, 12h: 1/3000, 13h: 1/4000, 14h: 1/6000, 15h: 1/10000(default)		Immediate reflection
Maximum Shutter Speed	7Ch	00h: 1/4(default), 01h: 1, 02h: 1/2, 03h: 1/3, 04h: 1/4, 05h: 1/6, 06h: 1/8, 07h: 1/15 or 1/12.5		Immediate reflection
Setup Control	7Dh	2Bh	Restore Parameters to factory default	Reflected after camera reset

3.31 Title Display

Data can be set using Commands in CAM_MultiLineTitle Command.

- The title composes of up to 12 lines. Each line can contain up to 20 characters.
- Each line can be individually set to display on/off.
- The top-left X and Y position (every 20 pixels) of title display area and font size (4 sizes) can be set.

Title Display Setting Command List

Command Set	Command	Command Packet															Comments	
		H	1	2	3	4	5	6	7	8	9	10	11	12	13	14		15
CAM_MultiLineTitle	Title Set1	8x	01	04	73	10	00	nn	pp	0q	00	00	00	00	00	00	FF	nn: Title start point X (1 unit = 20 pixel, 00h~7Fh) pp: Title start point Y (1 unit = 20 pixel, 00h~7Fh) q: Font size [0 (smallest) - 3 (largest)]
	Title Set2	8x	01	04	73	2L	mm	nn	pp	qq	rr	ss	tt	uu	vv	ww	FF	L: Line Number mnpqrstuvw: Character Font Number (1 to 10)
	Title Set3	8x	01	04	73	3L	mm	nn	pp	qq	rr	ss	tt	uu	vv	ww	FF	L: Line Number mnpqrstuvw: Character Font Number (11 to 20)
	Title Clear	8x	01	04	74	1p	FF											p: 0 to Bh line, p=Fh: all lines
	On	8x	01	04	74	2p	FF											p: 0 to Bh line, p=Fh: all lines
	Off	8x	01	04	74	3p	FF											p: 0 to Bh line, p=Fh: all lines

Table: Character Code (Font Number)

Font Number	00	01	02	03	04	05	06	07
Character	A	B	C	D	E	F	G	H
Font Number	08	09	0A	0B	0C	0D	0E	0F
Character	I	J	K	L	M	N	O	P
Font Number	10	11	12	13	14	15	16	17
Character	Q	R	S	T	U	V	W	X
Font Number	18	19	1A	1B	1C	1D	1E	1F
Character	Y	Z	&	[space]	?	!	1	2
Font Number	20	21	22	23	24	25	26	27
Character	3	4	5	6	7	8	9	0
Font Number	28	29	2A	2B	2C	2D	2E	2F
Character	a	b	c	d	e	f	g	h
Font Number	30	31	32	33	34	35	36	37
Character	i	j	k	l	m	n	o	p
Font Number	38	39	3A	3B	3C	3D	3E	3F
Character	q	r	s	t	u	v	w	x
Font Number	40	41	42	43	44	45	46	47
Character	y	z	%	[]	*	+	=
Font Number	48	49	4A	4B	4C	4D	4E	4F
Character	_	"	:	'	.	,	/	-

Example: The point located in $x = 100$ ($20 \times 5h$) pix/ $y = 220$ ($20 \times Bh$) pix from the upper left corner of a screen is designated as the starting point. "V5r%" is displayed on the 3rd line in max. size.

- Title Set1: 8x 01 04 73 10 00 05 0B 03 00 00 00 00 00 FF

(Set the coordinate and font size)

- Title Set2: 8x 01 04 73 22 15 22 39 42 1B 1B 1B 1B 1B 1B FF

(Set the characters displayed on the 3rd line)

- On: 8x 01 04 74 22 FF

(Display the "3rd " line)

3.32 Privacy Zone Masking Function

Privacy zone masking protects private objects and areas such as house windows, entrances and exits. Privacy zone masking masks such subjects which are within the camera's range of vision, on the monitor.

MP3010M-EV complies with the three-dimension privacy zone masking which enables to process the mask for Pan/Tilt/Zoom movement by receiving Pan/Tilt/Zoom VISCA Command.

Data can be set using Commands in CAM_PrivacyZone Command.

Features

1. Mask can be set on up to 8 places according to Pan/Tilt positions.
2. Mask can be displayed on 8 places per screen simultaneously.
3. Individual on/off zone masking settings.
4. Two colors can be individually set for each of 8 privacy zones.
5. Interlocking control with Pan/Tilt/Zoom.
6. Non-interlocking control with Pan/Tilt.

Privacy Zone Mask Command List

Command Set	Command	Command Packet															Comments	
		H	1	2	3	4	5	6	7	8	9	10	11	12	13	14		15
CAM_PrivacyZone	SetMask	8x	01	04	76	0m	0n	0r	0r	0s	0s	FF						Setting Mask(Size) Parameter: 0m 0n 0r 0r 0s 0s m: mask number (0h-7h) n=0: Modify n=1: New rr: W ss: H
	Display	8x	01	04	77	0p	0p	0p	0p	FF								Setting Mask Display On/Off pppp: Mask setting (0: Off, 1: On)
	SetMaskColor	8x	01	04	78	0p	0p	0p	0p	qq	rr	FF						Setting Color of Mask pppp: Mask Color Setting qq: Color setting when setting the Mask bit to 0 rr: Color setting when setting the Mask bit to 1
	SetPanTiltAngle	8x	01	04	79	0p	0p	0p	0q	0q	0q	FF						Setting Pan/Tilt Angle ppp: Pan angle, qq: Tilt angle
	SetPTZMask	8x	01	04	7B	0m	0p	0p	0p	0q	0q	0r	0r	0r	0r	0r	FF	Setting the direct position of PTZ m: mask number, ppp: Pan, qq: Tilt, rrrr: Zoom
	Non_InterlockMask	8x	01	04	6F	0m	0p	0p	0q	0q	0r	0s	0s	FF				Setting non-interlocking the mask to pan/tilt m: mask number, pp: X, qq: Y, rr: W, ss: H

Parameters pp : x、qq : y、rr : w、 ss : h

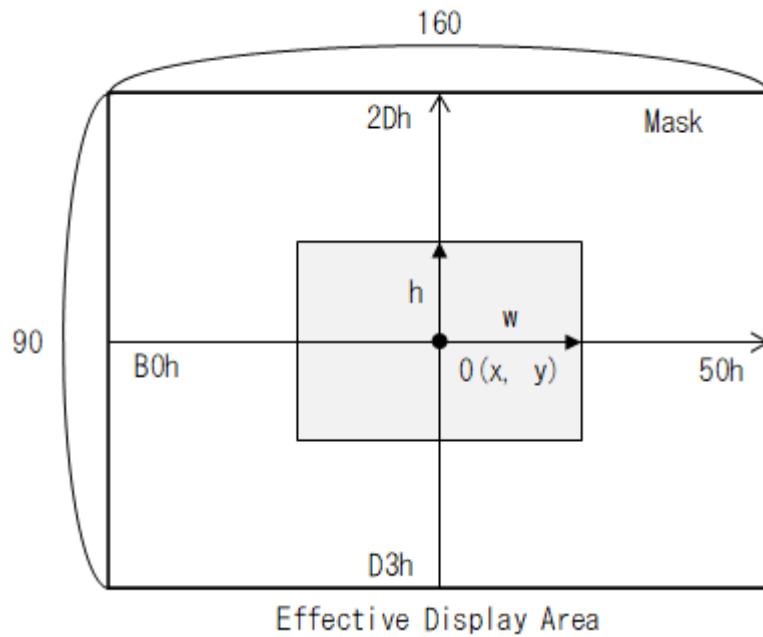

Note:

The priority order of the mask display is in the sequence from 0 (lowest) to 7 (highest). When you set the parameters of masks non-sequentially, it is recommended that you set the mask whose priority order is higher, first.

Display

Display the mask. Each mask can be turned On/Off individually.

Command	Command Packet															
	H	1	2	3	4	5	6	7	8	9	10	11	12	13	14	15
Display	8x	01	04	77	0p	0p	0p	0p	FF							

Each bit represents each mask and “1” turns on the mask and “0” turns off the mask.

0p 0p 0p 0p : マスクビット

	0p								0p								0p								0p							
bit	7	6	5	4	3	2	1	0	7	6	5	4	3	2	1	0	7	6	5	4	3	2	1	0	7	6	5	4	3	2	1	0
Mask	-	-	-	-	-	-	7	6	-	-	-	-	-	-	5	4	-	-	-	-	-	-	3	2	-	-	-	-	-	-	1	0

SetMaskColor

Set color of masks.

Command	Command Packet															
	H	1	2	3	4	5	6	7	8	9	10	11	12	13	14	15
SetMaskColor	8x	01	04	78	0p	0p	0p	0p	qq	rr	FF					

2 out of 14 colors can be selected as mask color. The color of each mask is decided by mask bit setting of 1/0. It becomes a color code qq by setting 0, and it becomes a color code rr by setting 1.

The relation of mask/bit position and pp are the same as Display section.

Set a color of each mask with this command before turning on the Display.

Op Op Op Op: Mask bit

	Op								Op								Op								Op							
Bit	7	6	5	4	3	2	1	0	7	6	5	4	3	2	1	0	7	6	5	4	3	2	1	0	7	6	5	4	3	2	1	0
Mask	-	-	-	-	-	-	7	6	-	-	-	-	-	-	5	4	-	-	-	-	-	-	3	2	-	-	-	-	-	-	1	0

qq, rr: Color Code

Mask(Color)	Code(qq,rr)
Black	00h
Gray1	01h
Gray2	02h
Gray3	03h
Gray4	04h
Gray5	05h
Gray6	06h

Mask(Color)	Code(qq,rr)
White	07h
Red	08h
Green	09h
Blue	0Ah
Cyan	0Bh
Yellow	0Ch
Magenta	0Dh

SetPanTiltAngle

Set the present angle of pan and tilt.

Command	Command Packet															
	H	1	2	3	4	5	6	7	8	9	10	11	12	13	14	15
SetPanTiltAngle	8x	01	04	79	0p	0p	0p	0q	0q	0q	FF					

ppp indicates Pan-angle, qqq indicates Tilt-angle. The values are 0-FFFh. Therefore, 360 degrees is divided into 4096 and resolution is about 0.088 degree.

This command informs the angle of current pan and tilt to the camera.

The camera will calculate position of the mask with the information.

Setting Pan/Tilt Angle

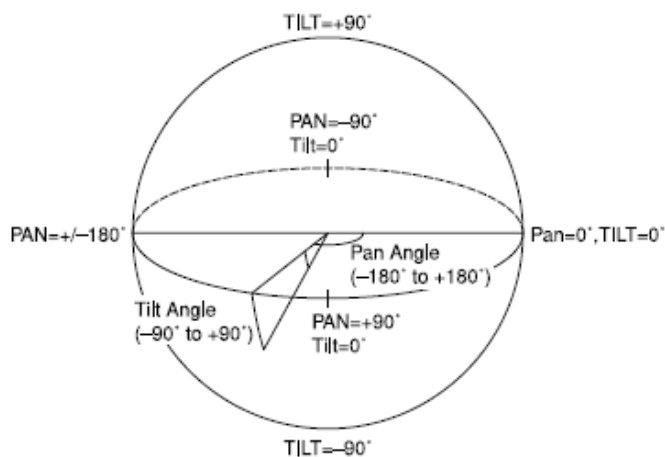
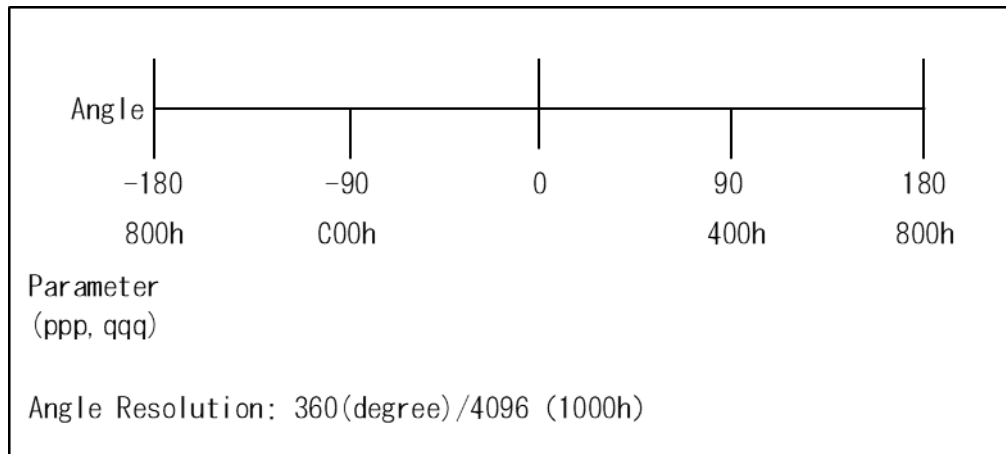

SetPTZMask

Set Pan/Tilt/Zoom position of each mask directly.

Command	Command Packet															
	H	1	2	3	4	5	6	7	8	9	10	11	12	13	14	15
SetPTZMask	8x	01	04	7B	0m	0p	0p	0p	0q	0q	0q	0r	0r	0r	0r	FF

ppp: Pan Angle, qq: Tilt Angle, rrrr: Zoom Position

Non_InterlockMask

Set a mask that does not link to Pan/Tilt movement but link to Zoom movement.

Command	Command Packet															
	H	1	2	3	4	5	6	7	8	9	10	11	12	13	14	15
Non_InterlockMask	8x	01	04	6F	0m	0p	0p	0q	0q	0r	0r	0s	0s	FF		

As for the value of x, y, w, and h, please refer to the explanation of the parameter in the above command list.

Setting orders

1. Select color by **SetMaskColor** command. Choose 2 of 14 colors and set the color in each mask.
2. Move and face the camera to the target by setting **SetPanTiltAngle**. Zoom level is set by zoom command.
3. Execute **SetMask**.
4. Set mask on or off by **Display** command. 1=On 0=Off on the value p.
5. Set the mask size with some margin to cover an error range. Make sure the target is covered or not by moving the camera.
6. The set up condition will be gone when turn off the power. To keep the set up condition Custom pre-set is recommended.

3.33 Keystone Correction

The upper edge of the keystone image can be expanded by Keystone Correction.

Compensation Level: Step1 (lowest) - Step18 (Highest)

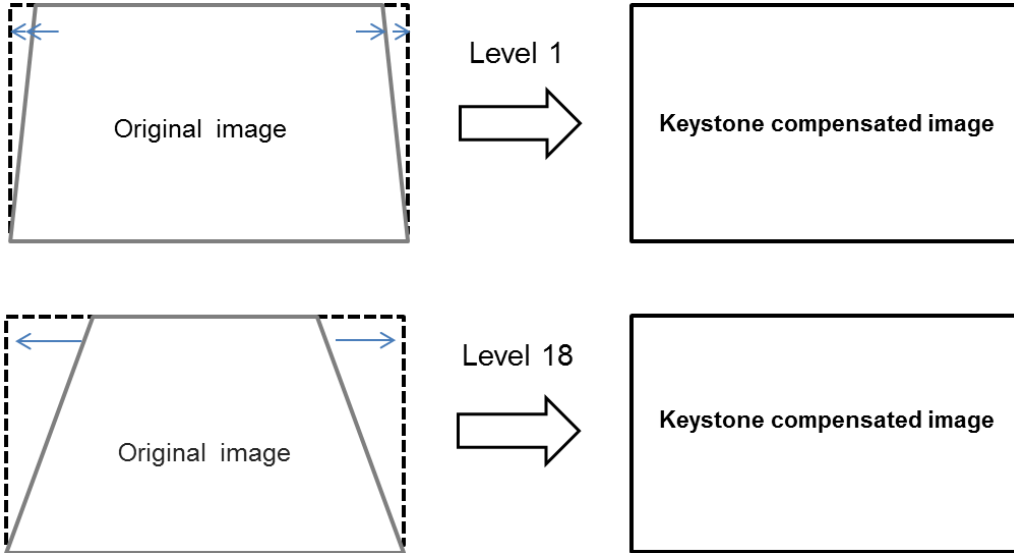

Command Set	Command	Command Packet														Comments				
		H	1	2	3	4	5	6	7	8	9	10	11	12	13		14	15		
CAM_RegisterValue	-	8x	01	04	24	60	Op	0q	FF											addr = 60h: Keystone correction pq: 00h=Off, 01h=correction low, ..., 12h=correction high

3.34 Lens Distortion Correction

Barrel distortion and pincushion distortion correction supported.

The register setting command can set and change the LDC default setting.

It uses Register Setting command and parameters are the following.

Register Setting command (CAM_Register Value command) :

8x 01 04 24 78 0p 0p FF

p (upper 4bit): Select image

0: cropped image

1: complete image

Note: Pay attention to the followings when using complete image (p=1).

- Pixel aspect becomes vertically long a little

- During zooming, discontinuous point occurs

p (lower 4bit): Strength parameter of Lens Distortion Correction (0 to 4)

0: Off

1: weak barrel correction to wide-end, no pincushion correction to tele-end

2: strong barrel correction to wide-end, no pincushion correction to tele-end

3: strong barrel correction to wide-end, strong pincushion correction to tele-end

4: same as 1

Default value is 2.

3.35 Zoom Position Limit

Sets the limit position in the zoom range.

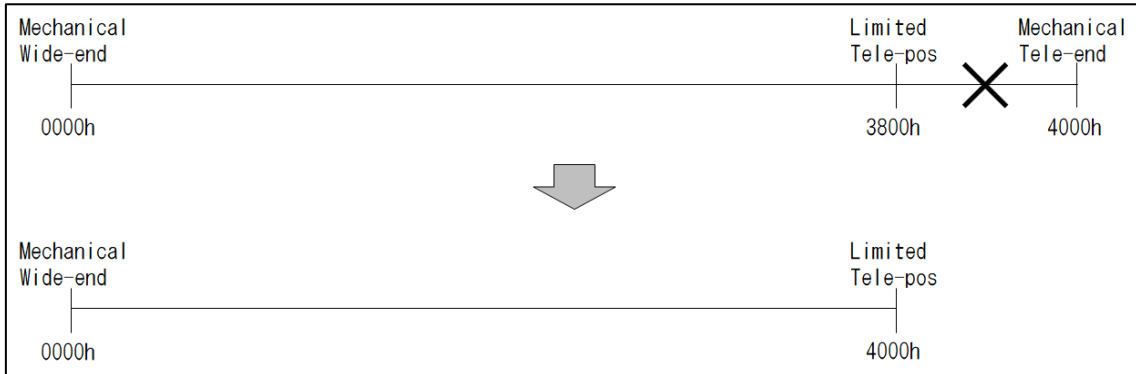

Uses Register Setting command and parameters are the following

Register name	Resister No.	Setting value	Setting value Reflecting timing
Opt zoom limit(W-end)	50h	00h(Default) - EFh	after reboot
Opt zoom limit(T-end)	51h	00h(Default) - EFh	after reboot

Example: To set Zoom Limit Tele

81 01 04 24 51 0p 0q FF (pq = Parameter)

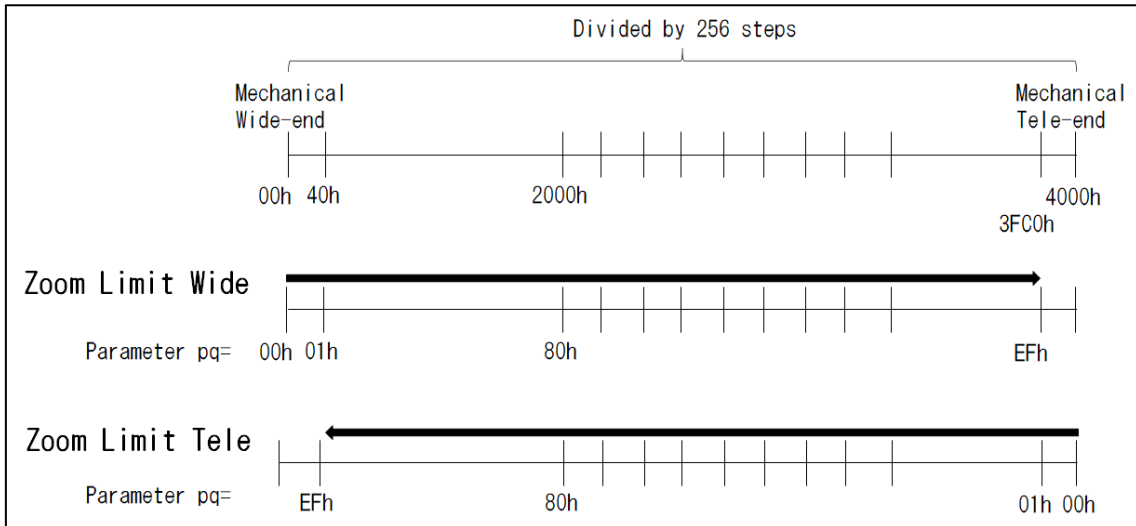

3.36 Initial Settings, Custom Presets

Initial settings for the various functions of the camera module are indicated in the “Initial Setting” row. It is same meaning of Factory Default.

For “Custom Preset”, use VISCA CUSTOM command to save all parameters except parameters set by register setting (CAM_RegisterValue Command). When the camera is powered on, the parameters set by VISCA CUSTOM command, are recalled automatically.

Parameters except parameters set by Register Setting (CAM_RegisterValue Command) can be saved.

Reset

Clear the saved data.

Set

Save the current data.

Recall

Read the saved data.

Mode/Position Setting	Initial Setting (Factory Default)
Zoom Position	0000h(Wide End)
Digital Zoom On/Off	Off
Focus Position	1000h(Infinity)
Focus Auto/Manual	Auto
Near Limit Setting	8000h(25 cm)
AF Sensitivity	Normal
AF Mode	Normal AF
AF Run Time	5 sec
AF Interval	5 sec
IR Correction	Standard
Vibration Compensation	Off
WB Mode	ATW1
One Push WB Data	-
WB Data(Rgain, Bgain)	-
AE Mode	Full Auto
Slow Shutter Mode	Manual
Shutter Position	05h(1/30 or 1/25)
Iris Position	11h(F1.6)
Gain Position	01h(0dB)
Gain Limit	1Ch(+54dB)
Exposure Compensation On/Off	Off
Exposure Compensation Amount	07h(0dB)
BackLight Compensation On/Off	Off
SpotAE On/Off	Off
SpotAE Position Setting	X: 07h, Y: 07h
Flicker Detection On/Off	Off
AE Response	10h(01h - 30h)
WD On/Off	Off
Defog On/Off	Off
Aperture Level	08h
3DNR Level	03h(Middle)
2DNR Level	03h(Middle)
Gamma	0h: Standard Gamma
LR Reverse On/Off	Off
Picture Effect	Off
E-Flip On/Off	Off
ICR On/Off	Off
Auto ICR	Off
Auto ICR Alarm Reply	Off
Title Setting	-
Title Display On/Off	Off
Privacy Zone Mask Setting	-
Privacy Zone Mask Display On/Off	Off
Privacy Zone Mask Color Setting	-
CAM_CenterLine	Off
ZoomPos Continuous Output On/Off	Off
ZoomPos Continuous Output Interval	3Ch(60 frames)
Low-Illumination Chroma Suppress	02h(Middle)
Color Gain	04h(100%)
Color Hue	07h(0 degree)
AutoTempAlarmReply	On

4. VISCA Commands

4.1 VISCA/RS-232C Commands

This chapter outlines an RS-232C control protocol and command list for MP3010M-EV. THIS CONTROL PROTOCOL AND COMMAND LIST IS PROVIDED BY TAMRON WITHOUT WARRANTY OF ANY KIND. THIS CONTROL PROTOCOL AND COMMAND LIST SHOULD BE USED WITH CAUTION.

4.2 Overview of VISCA

In VISCA, the device outputting commands, for example a computer, is called “controller”. The device receiving the commands, a camera module is called “peripheral device”. In VISCA, the camera module can be connected to a controller using communication conforming to the RS-232C standard. The parameters of RS-232C are as follows.

- Communication speed: 9.6 kbps/19.2 kbps/38.4 kbps/115.2 kbps
- Data bits : 8
- Start bit : 1
- Stop bit : 1
- Non parity

Flow control using XON/XOFF and RTS/CTS, etc., is not supported.

* VISCA is a protocol which controls consumer camcorders developed by Sony. “VISCA” is a registered trademark of Sony Corporation.

4.3 VISCA Communication Specifications

VISCA Packet Structure

The basic unit of VISCA communication is called a packet. The first byte of the packet is called a header and comprises the sender's and receiver's addresses. For example, the header of the packet sent to the camera module assigned address 1 from the controller (address 0) is hexadecimal 81h. The packet sent to the camera module assigned address 2 is 82h. In the command list, the header is 8x where x is the address of the camera module. The header of the reply packet from the camera module assigned address 1 is 90h. The packet from the camera module assigned address 2 is A0h.

Some of the commands for setting camera modules can be sent to all devices at one time (broadcast). In the case of broadcast, the header should be hexadecimal 88h. The terminator is FFh. It signifies the end of the packet.

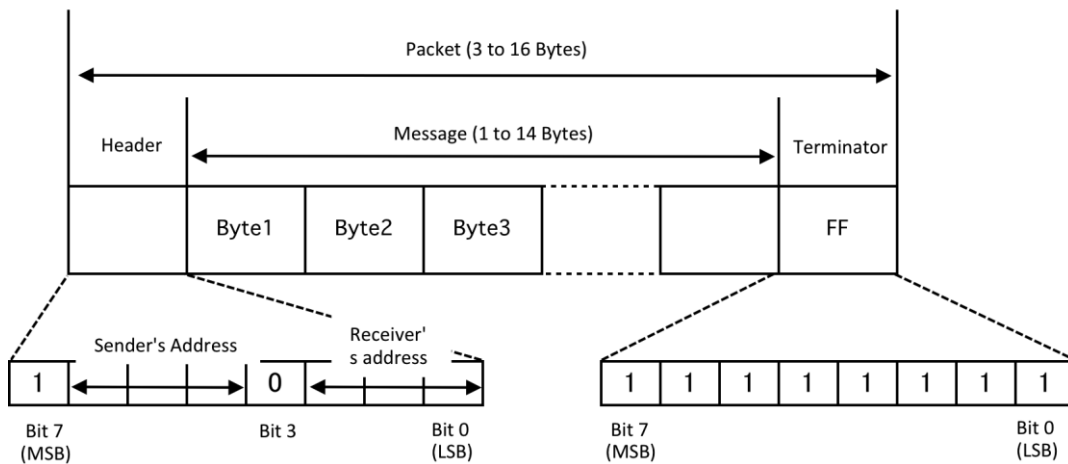

Commands and Inquiries

- **Command**
Sends operational commands to the camera.
- **Inquiry**
Used for inquiring about current state of the camera.

	Command Packet	Note
Inquiry	8x QQ RRFF	QQ ¹⁾ = Command/Inquiry RR ²⁾ = category code

¹⁾ QQ = 01(Command), 09(Inquiry)

²⁾ RR = 00(Interface), 04(Camera1), 06(Pan/Tilter), 07(Camera2)

X = 1 to 7 : camera address

Responses for commands and inquiries

- **ACK Message**
Returned by the camera when it receives a command. No ACK message is returned for inquiries.
- **Completion Message**
Returned by the camera when execution of commands or inquiries is completed. In the case of inquiry commands, it will contain reply data for the inquiry after the 3rd byte of the packet. If the ACK message is omitted, the socket number will contain 0.

	Reply Packet	Note
Ack	X0 4Y FF	Y = socket number
Completion (commands)	X0 5Y FF	Y = socket number
Completion (Inquiries)	X0 5Y ... FF	Y = socket number

X = 9 to F: camera address +8

- **Error Message**

When a command or inquiry command could not be executed or failed, an error message is returned instead of the completion message.

Error Packet	Description
X0 6Y 01 FF	Message length error (>14 bytes)
X0 6Y 02 FF	Syntax Error
X0 6Y 03 FF	Command buffer full
X0 6Y 04 FF	Command cancelled
X0 6Y 05 FF	No socket (to be cancelled)
X0 6Y 41 FF	Command not executable

X = 9 to F: camera address +8, Y = socket number

Socket Number

When a command message is sent to a camera, it is common to send the next command message after waiting for the completion message or error message returned. However, to deal with advanced uses, a camera has two buffers (memories) for commands, so that up to two commands including the commands currently being executed can be received. When a camera receives a command, it notifies the sender which command buffer was used, by using the socket number of the ACK message. As the completion message or the error message also has a socket number, it indicates which command has ended. Even when two command buffers are being used at any one time, a camera management command and some inquiry messages can be executed. An ACK message is not returned for these commands and inquiries, and only the completion message of socket number 0 is returned.

Command Execution Cancel

To cancel a command which has already been sent, send the Cancel command (CommandCancel Command) as the next command. To cancel one of any two commands which have been sent, use the cancel message.

	Cancel Packet	Note
Cancel	8X 2Y FF	Y = socket number
X = 1 to 7: camera address, Y = socket number		

An error message (Command Cancelled) will be returned for this command, but it is not a fault. It indicates that the command has been canceled.

4.4 VISCA Device Setting Commands

VISCA is a protocol, which normally supports a daisy chain of up to seven connected cameras via RS-232C interface.

Before starting control of the camera module, be sure to send AddressSet Command and IF_Clear Command as broadcast.

For VISCA Network Administration

- **AddressSet Command**

Sets an address of a peripheral device. Use this when initializing the network, or receiving the following network change message.

- **Network Change**

Sent from a peripheral device to a controller when the device is removed from or added to the network. The address must be re-set when this message is received.

	Packet	Note
Address	88 30 01 FF	Always broadcasted.
Network Change	X0 38 FF	
X = 9 to F: camera address +8		

VISCA Interface Commands

• IF_Clear Command

Clears the command buffers in the camera and cancels the command currently being executed.

	Command Packet	Reply Packet	Note
IF_Clear	8X 01 00 01 FF	X0 50 FF	
IF_Clear (broadcast)	88 01 00 01 FF	88 01 00 01 FF	
X = 1 to 7: camera address (For inquiry packet)			
X = 9 to F: camera address +8 (For reply packet)			

VISCA Interface and Inquiry

• CAM_VersionInq

Returns information of the VISCA interface.

Inquiry	Inquiry Packet	Reply Packet	Description
CAM_VersionInq	8X 09 00 02 FF	Y0 50 GG GG HH HH JJ JJ KK FF	GGGG = Vender ID (0023: TAMRON) HHHH = Model ID (F017 : MP3010M-EV) JJJJ = ROM revision KK = Maximum socket #(02)

X = 1 to 7: camera address (For inquiry packet)

Y = 9 to F: camera address +8 (For reply packet)

4.5 VISCA Commands/ACK Protocol

Command	Command	Reply Message	Comments
General Command	81 01 04 38 02 FF (Example)	90 41 FF (Acknowledge) +90 51 FF(Completion) 90 42 FF 90 52 FF	Returns Acknowledge when a command has been accepted, and Completion when a command has been executed.
	81 01 04 38 FF (Example)	90 60 02 FF(Syntax Error)	Accepted a command which is not supported or a command lacking parameters.
	81 01 04 38 02 FF (Example)	90 60 03 FF (Command Buffer Full)	There are two commands currently being executed, and the command could not be accepted.
	81 01 04 08 02 FF (Example)	90 61 41 FF (Command Not Executable) 90 62 41FF	Could not execute the command in the current mode.
Inquiry Command	81 09 04 38 FF (Example)	90 50 02 FF(Completion)	Acknowledge is not returned for the inquiry command.
	81 09 05 38 FF (Example)	90 60 02 FF(Syntax Error)	Accepted an incompatible command.
Address Set	88 30 01 FF	88 30 02 FF	Returned the device address to +1.
IF_Clear(Broadcast)	88 01 00 01 FF	88 01 00 01 FF	Returned the same command.
IF_Clear(For x)	8x 01 00 01 FF	z0 50 FF (Completion)	Acknowledge is not returned for this command.
Command Cancel	8x 2y FF	z0 6y 04 FF (Command Canceled)	Returned when the command of the socket specified is canceled. Completion for the command canceled is not returned.
		z0 6y 05 FF (No Socket)	Returned when the command of the specified socket has already been completed or when the socket number specified is wrong.

4.6 VISCA Camera-Issued Messages

ACK/Completion Messages

	Command Message	Comments
Acknowledge	z0 4y FF(y:Socket No.)	Returned when the command is accepted.
Completion	z0 5y FF(y:Socket No.)	Returned when the command has been executed.

z = 9 to F: Device address +8

Error Messages

	Command Message	Comments
Syntax Error	z0 60 02 FF	Returned when the command format is different or when a command with illegal command parameters is accepted.
Command Buffer Full	z0 60 03 FF	Indicates that two sockets are already being used (executing two commands) and the command could not be accepted when received.
Command Canceled	z0 6y 04 FF(y:Socket No.)	Returned when a command which is being executed in a socket specified by the cancel command is canceled. The completion message for the command is not returned.
No Socket	z0 6y 05 FF(y:Socket No.)	Returned when no command is executed in a socket specified by the cancel command, or when an invalid socket number is specified.
Command Not Executable	z0 6y 41 FF(y:Socket No.)	Returned when a command cannot be executed due to current conditions. For example, when commands controlling the focus manually are received during auto focus.

z = 9 to F: Device address +8

Network Change Message

	Command Message	Comments
Network Change	z0 38 FF	Issued when power is being routed.

z = 9 to F: Device address +8

4.7 VISCA Command List

Command List (1/2)

Command Set	Command	Command Packet															Comments	Initial Value Factory Default	
		H	1	2	3	4	5	6	7	8	9	10	11	12	13	14			15
AddressSet	Broadcast	88	30	0x	FF													Address Setting Supports daisy chain addressing a nearest camera (x1 to 7)	
F_Clear	Broadcast	88	01	00	01	FF												/F Clear (Broadcast)	
CommandCancel	For x	8x	01	00	01	FF												/F Clear (For x)	
CAM_Power	On	8x	01	04	00	02	FF											Power on	On
	Off (Standby)	8x	01	04	00	03	FF											Power off (standby mode: VISCA commands are acceptable)	
CAM_Zoom	Stop	8x	01	04	07	00	FF												
	Tele (Standard)	8x	01	04	07	02	FF												
	Wide (Standard)	8x	01	04	07	03	FF												
	Wide (Variable)	8x	01	04	07	3p	FF												
CAM_DZoom	Direct	8x	01	04	07	0p	FF												
	On	8x	01	04	06	02	FF												
CAM_Focus	Stop	8x	01	04	08	00	FF												
	Far (Standard)	8x	01	04	08	02	FF												
	Near (Standard)	8x	01	04	08	03	FF												
	Far (Variable)	8x	01	04	08	2p	FF												
	Near (Variable)	8x	01	04	08	3p	FF												
	Direct	8x	01	04	48	0p	FF												
	Auto Focus	8x	01	04	38	02	FF												
	Manual Focus	8x	01	04	38	03	FF												
	Auto/Manual	8x	01	04	38	04	FF												
	One Push Trigger	8x	01	04	18	01	FF												
CAM_AF Sensitivity	Near Limit	8x	01	04	28	0p	FF												
	High	8x	01	04	58	03	FF												
	Normal	8x	01	04	58	02	FF												
	Low	8x	01	04	58	01	FF												
CAM_AFMode	Interval AF	8x	01	04	57	01	FF												
	Zoom Trigger AF	8x	01	04	57	02	FF												
CAM_IRCorrection	Standard	8x	01	04	11	01	FF												
	IR Light	8x	01	04	11	01	FF												
CAM_VibrationCompensation	On	8x	01	04	34	02	FF												
	Off	8x	01	04	34	03	FF												
CAM_ZoomFocus	Hold	8x	01	04	34	00	FF												
	Direct	8x	01	04	47	0p	FF												
CAM_Initialize	Lens	8x	01	04	19	01	FF												
	Camera	8x	01	04	19	02	FF												
CAM_WB	ATW1	8x	01	04	35	00	FF												
	Indoor	8x	01	04	35	01	FF												
	Outdoor	8x	01	04	35	02	FF												
	One Push WB	8x	01	04	35	03	FF												
	Manual	8x	01	04	35	04	FF												
CAM_RGain	Reset	8x	01	04	10	05	FF												
	Up	8x	01	04	03	02	FF												
CAM_BGain	Down	8x	01	04	03	03	FF												
	Direct	8x	01	04	43	00	FF												
CAM_AE	Reset	8x	01	04	04	02	FF												
	Up	8x	01	04	04	03	FF												
CAM_SlowShutter	Direct	8x	01	04	44	00	FF												
	Full Auto	8x	01	04	39	03	FF												
CAM_Shutter	Shutter Priority/Tv	8x	01	04	39	04	FF												
	Full Auto	8x	01	04	39	05	FF												
CAM_Iris	Reset	8x	01	04	03	01	FF												
	Up	8x	01	04	03	02	FF												
CAM_Gain	Down	8x	01	04	03	03	FF												
	Direct	8x	01	04	43	00	FF												
CAM_ExpComp	Reset	8x	01	04	0E	00	FF												
	Up	8x	01	04	0E	01	FF												
CAM_BackLight	Down	8x	01	04	0E	02	FF												
	Direct	8x	01	04	4E	00	FF												
CAM_AE Response	Reset	8x	01	04	0E	00	FF												
	Up	8x	01	04	0E	01	FF												
CAM_WD	Down	8x	01	04	33	02	FF												
	Direct	8x	01	04	33	03	FF												
CAM_Defog	On	8x	01	04	59	02	FF												
	Off	8x	01	04	59	03	FF												
CAM_Aperture/Sharpness	Position	8x	01	04	29	0p	FF												
	On	8x	01	04	09	02	FF												
CAM_Gamma	Off	8x	01	04	09	03	FF												
	Direct	8x	01	04	5D	0p	FF												
CAM_LR_Reverse	Reset	8x	01	04	02	00	FF												
	Up	8x	01	04	02	01	FF												
CAM_PICTUREEffect	Down	8x	01	04	02	02	FF												
	Direct	8x	01	04	42	00	FF												
CAM_ICR	Reset	8x	01	04	53	0p	FF												
	On	8x	01	04	53	01	FF												
CAM_AutoICR	Flip On	8x	01	04	66	03	FF												
	Flip Off	8x	01	04	66	04	FF												
CAM_AutoICRAlarmReply	On	8x	01	04	01	02	FF												
	Off	8x	01	04	01	03	FF												
CAM_Memory	On	8x	01	04	51	03	FF												
	Threshold	8x	01	04	21	00	FF												
CAM_CUSTOM	On	8x	01	04	31	02	FF												
	Off	8x	01	04	31	03	FF												
CAM_CUSTOM	Reset	8x	01	04	3F	00	FF												
	Set	8x	01	04	3F	01	FF												
CAM_CUSTOM	Recall	8x	01	04	3F	02	FF												
	Set	8x	01	04	3F	03	FF												

Command List (2/2)

Command Set	Command	Command Packet															Comments	Initial Value Factory Default			
		H	1	2	3	4	5	6	7	8	9	10	11	12	13	14			15		
CAM_MultiLineTitle	Title Set1	8x	01	04	73	10	00	nn	pp	qq	00	00	00	00	00	00	FF	m: Title start point X (1 unit = 20 pixel, 00h - 7Fh) pp: Title start point Y (1 unit = 20 pixel, 00h - 7Fh) q: Font size [0 (smallest) - 3 (largest)]	m=05h, pp=05h, q=3h		
	Title Set2	8x	01	04	73	2L	mm	nn	pp	qq	rr	ss	tt	uu	vv	ww	FF	L: Line Number m:pp:stuvw: Character Font Number (1 to 10)			
	Title Set3	8x	01	04	73	3L	mm	nn	pp	qq	rr	ss	tt	uu	vv	ww	FF	L: Line Number m:pp:stuvw: Character Font Number (1 to 20)			
	Title Clear	8x	01	04	74	1p	FF											p: 0 to Bn line, p:Fh: all lines			
	On	8x	01	04	74	2p	FF											p: 0 to Bn line, p:Fh: all lines			
CAM_Mute	Off	8x	01	04	75	03	FF											Mute On/Off	Off		
	On/Off(Toggle)	8x	01	04	75	10	FF											Mute On/Off	Off		
CAM_PrivacyZone	SetMask	8x	01	04	76	0m	0n	0r	0s	0s	FF							Setting Mask(Size) Parameter: 0m: On 0n: Or 0s: Os m: mask number (0h-7h) n=0: Modify n=1: New r: W s: H			
	Display	8x	01	04	77	0p	0p	0p	0p	0p	FF							Setting Mask Display On/Off pppp: Mask setting (0: Off, 1: On)			
	SetMaskColor	8x	01	04	78	0p	0p	0p	0p	0q	0q	0q	0q	0q	0q	0q	0q	FF	Setting Color of Mask pppp: Mask Color Setting qq: Color setting when setting the Mask bit to 0 rr: Color setting when setting the Mask bit to 1		
	SetPanTiltAngle	8x	01	04	79	0p	0p	0p	0q	0q	0q	0q	0q	0q	0q	0q	0q	0q	FF	Setting Pan/Tilt Angle pppp: Pan angle, qq: Tilt angle	
CAM_CenterLine	SetPTZMask	8x	01	04	7B	0m	0p	0p	0p	0q	0q	0q	0r	0r	0r	0r	0r	FF	Setting the direct position of PTZ m: mask number, ppp: Pan, qq: Tilt, rrrr: Zoom		
	Non_InterlockMask	8x	01	04	6F	0m	0p	0p	0p	0q	0r	0r	0s	0s	0s	0s	0s	FF	Setting non-interlocking the mask to pan/tilt m: mask number, pp: X, qq: Y, rr: W, ss: H		
CAM_ContinuousZoomPosReply	CenterLineOff	8x	01	04	7C	03	FF											Setting CenterLine Display Off	0h		
	CenterLineOn	8x	01	04	7C	04	FF											Setting CenterLine Display On	0h		
CAM_ReplyIntervalTimeSet	On	8x	01	04	69	03	FF											ZoomPosition data Continuous Output On/Off	0h		
	Off	8x	01	04	6A	00	00	0p	0p	0p	FF							pp: Interval Time (Vertical timing) [frame count]	3Ch		
CAM_RegisterValue		8x	01	04	24	00	0p	0q	0q	0q	0q	0q	0q	0q	0q	0q	0q	FF	addr = 00h: VSCA communication baud rate pp: 00h=500bps, 01h=1000bps, 02h=38400bps, 03h=115200bps	00h	
		8x	01	04	24	20	0p	0q	0r	0s	0s	FF							addr = 20h: Focus detecting area selection Start pos = (x1, y1), End pos = (x2, y2) pp: x1, y1, r: x2, y2 (1 ≤ x1 < x2 ≤ 7, 1 ≤ y1 < y2 ≤ 7)	p=3h, q=3h r=5h, s=5h	
		8x	01	04	24	21	0p	0q	0q	0q	0q	0q	0q	0q	0q	0q	0q	0q	FF	addr = 21h: Focus stop position In the case that AF can't find a focusing position pp: 10h=Over inf, 11h-13h=Linear interpolation between Over inf and Inf, 14h=Inf, 15h-17h=Linear interpolation between Inf and 4.7m, 20h=4.7m, 21h-23h=Linear interpolation between 4.7m and 2.3m..., 80h=1.0cm	80h (=25cm)
		8x	01	04	24	50	0p	0q	0q	0q	0q	0q	0q	0q	0q	0q	0q	0q	FF	addr = 50h: Opt zoom limit (W-end) pp: 00h (No limit) - 6Fh	00h
		8x	01	04	24	51	0p	0q	0q	0q	0q	0q	0q	0q	0q	0q	0q	0q	FF	addr = 51h: Opt zoom limit (T-end) pp: 00h (No limit) - 6Fh	00h
		8x	01	04	24	52	0p	0q	0q	0q	0q	0q	0q	0q	0q	0q	0q	0q	FF	addr = 52h: D-Zoom Max pp: 00h-F0h = D-ZoomPos / 64 - 256 (ex: 00h=x1, 80h=x2, C0h=x4, E0h=x8, EAh=x12, F0h=x16)	EAh
		8x	01	04	24	54	0p	0q	0q	0q	0q	0q	0q	0q	0q	0q	0q	0q	FF	addr = 54h: Zoom tracking pp: 00h=Off, 01h=On	01h
		8x	01	04	24	60	0p	0q	0q	0q	0q	0q	0q	0q	0q	0q	0q	0q	FF	addr = 60h: Keystone correction pp: 00h=Off, 01h=correction low, ..., 12h=correction high	00h
		8x	01	04	24	60	0p	0q	0q	0q	0q	0q	0q	0q	0q	0q	0q	0q	FF	addr = 72h: Monitor mode	
		8x	01	04	24	72	0p	0q	0q	0q	0q	0q	0q	0q	0q	0q	0q	0q	FF	LVDS: CVBS pp: 01h=1080/30p, 02h=1080/25p, 05h=720/60p, 06h=720/50p, 07h=1080/60p, 08h=1080/50p, 09h=720/59.94p, 08h=NTSC, 0Dh=PAL, 0Eh=720/29.97p, 0Fh=720/30p, 11h=720/25p, 13h=1080/59.94p, 14h=1080/29.97p, 18h=NTSC(Side cut), 1Dh=PAL(Side cut)	01h
		8x	01	04	24	74	0p	0q	0q	0q	0q	0q	0q	0q	0q	0q	0q	0q	FF	LVDS: CVBS pp: 40h=1080/30p, 41h=1080/25p, 42h=720/60p, 43h=720/50p, 44h=1080/60p, 45h=1080/50p, 46h=720/59.94p, 47h=1080/30p+NTSC(LB), 48h=1080/25p+PAL(LB), 49h=720/29.97p, 4A=720/30p, 4B=720/25p, 4C=1080/59.94p, 4Dh=1080/29.97p	01h
		8x	01	04	24	74	0p	0q	0q	0q	0q	0q	0q	0q	0q	0q	0q	0q	FF	addr = 74h: LVDS mode pp: 00h=Single, 01h=Double	00h
		8x	01	04	24	78	0p	0q	0q	0q	0q	0q	0q	0q	0q	0q	0q	0q	FF	addr = 78h: Lens distortion compensation p: 0h: Cropped image, 1h: Complete image q: 0h=Off, 1h=low Barrel correction only, 2h=Barrel correction only, 3h=Barrel correction and Pincushion correction	02h
		8x	01	04	24	79	0p	0q	0q	0q	0q	0q	0q	0q	0q	0q	0q	0q	FF	addr = 79h: Maximum F number pp: 03h=F2.2, 04h=F1.6, 05h=F1.4, 06h=F1.1, 07h=F0.9, 08h=F0.8	06h
		8x	01	04	24	7A	0p	0q	0q	0q	0q	0q	0q	0q	0q	0q	0q	0q	FF	addr = 7Ah: F number for Small Aperture Elimination pp: 09h=F6.8, 0Ah=F5.6, 0Bh=F4.8, 0Ch=F4.0, 0Dh=F3.4, 0Eh=F2.8, 0Fh=F2.4, 10h=F2.0, 11h=F1.8	0Ch
8x	01	04	24	7B	0p	0q	0q	0q	0q	0q	0q	0q	0q	0q	0q	0q	FF	addr = 7Bh: Minimum Shutter Speed pp: 08h=1/250, 0Ch=1/350, 0Dh=1/500, 0Eh=1/725, 0Fh=1/1000, 10h=1/1500, 11h=1/2000, 12h=1/3000, 13h=1/4000, 14h=1/6000, 15h=1/10000	15h		
8x	01	04	24	7C	0p	0q	0q	0q	0q	0q	0q	0q	0q	0q	0q	0q	FF	addr = 7Ch: Maximum Shutter Speed pp: 00h=1/4, 01h=1/3, 02h=1/2, 03h=1/3, 04h=1/4, 05h=1/6, 06h=1/8, 07h=1/15 or 1/12.5	00h		
8x	01	04	24	7D	0p	0q	0q	0q	0q	0q	0q	0q	0q	0q	0q	0q	FF	addr = 7Dh: Setup Control pp: 2Bh=Restore Parameters to factory default			
CAM_ChromaSuppress	On	8x	01	04	5F	0p	0q	0q	0q	0q	0q	0q	0q	0q	0q	0q	0q	FF	pp: Chroma Suppress setting level 00h: Off 01h-03h: On (3 levels) Effect increases as the level number increases.	02h	
	Off	8x	01	04	5F	03	FF												pp: Color Gain Setting Oh (60%) - Eh (200%)	04h	
CAM_ColorGain	Direct	8x	01	04	49	00	00	00	0p	0p	0p	0p	0p	0p	0p	0p	0p	FF	pp: Color Gain Setting Oh (-14 degrees) - Eh (+14 degrees)	07h	
	Direct	8x	01	04	4F	00	00	00	0p	0p	0p	0p	0p	0p	0p	0p	0p	FF	pp: Color Gain Setting Oh (-14 degrees) - Eh (+14 degrees)	07h	
CAM_AutoTempAlarmReply	On	8x	01	04	6B	02	FF												Lens Temperature Alarm On	0n	
	Off	8x	01	04	6B	03	FF												Lens Temperature Alarm Off	0n	
	(Reply)	y0	07	04	6B	01	FF												High Temp Alarm Reply		
	(Reply)	y0	07	04	6B	00	FF												Safe Temp Alarm Reply		

Inquiry Command List (1/2)

Command Set	Command Packet					Inquiry Packet														Comments
	H	1	2	3	4	5	6	7	8	9	10	11	12	13	14					
CAM_PowerInq	8x	09	04	00	FF													Power On		
CAM_ZoomPosInq	8x	09	04	47	FF													Power Off (Standby)		
CAM_DZoomModelInq	8x	09	04	06	FF													pgs: Zoom Position		
CAM_FocusModelInq	8x	09	04	38	FF													Digital Zoom On		
CAM_FocusPosInq	8x	09	04	48	FF													Digital Zoom Off		
CAM_FocusNearLimitInq	8x	09	04	28	FF													Auto Focus		
CAM_AFSensitivityInq	8x	09	04	58	FF													Manual Focus		
CAM_AFModelInq	8x	09	04	57	FF													pgs: Focus Position		
CAM_AFTimeSettingInq	8x	09	04	27	FF													pgs: Near Focus Limit Position		
CAM_IRCorrectionInq	8x	09	04	11	FF													AF Sensitivity High		
CAM_WBModelInq	8x	09	04	35	FF													AF Sensitivity Normal		
CAM_RGainInq	8x	09	04	43	FF													AF Sensitivity Low		
CAM_BGainInq	8x	09	04	44	FF													AF Sensitivity Super Low		
CAM_AEModelInq	8x	09	04	39	FF													Normal AF		
CAM_SlowShutterModelInq	8x	09	04	5A	FF													Interval AF		
CAM_ShutterPosInq	8x	09	04	4A	FF													Zoom Trigger AF		
CAM_IRInq	8x	09	04	4B	FF													pg: Movement Time, rs: Interval Time		
CAM_GainPosInq	8x	09	04	4C	FF													Standard		
CAM_GainLimitInq	8x	09	04	2C	FF													IR Light		
CAM_ExpCompModelInq	8x	09	04	3E	FF													ATW1 (Narrow)		
CAM_ExpCompPosInq	8x	09	04	4E	FF													Indoor (3200K)		
CAM_BackLightModelInq	8x	09	04	33	FF													Outdoor (5800K)		
CAM_SpotAEModelInq	8x	09	04	59	FF													One Push WB		
CAM_SpotAEPoInq	8x	09	04	29	FF													ATW2 (Wide)		
CAM_FlickerInq	8x	09	04	09	FF													Manual		
CAM_AE_ResponseInq	8x	09	04	5D	FF													pg: R Gain		
CAM_WDModelInq	8x	09	04	3D	FF													pg: B Gain		
CAM_DefogModelInq	8x	09	04	37	FF													Full Auto		
CAM_ApertureInq	8x	09	04	42	FF													Auto LN		
CAM_NRModelInq	8x	09	04	53	FF													Manual		
CAM_GammaInq	8x	09	04	58	FF													Shutter Priority		
CAM_LR_ReverseModelInq	8x	09	04	61	FF													Iris Priority		
CAM_FREEZInq	8x	09	04	62	FF													Gain Priority		
CAM_PictureEffectModelInq	8x	09	04	63	FF													On		
CAM_PictureFlipModelInq	8x	09	04	66	FF													Off		
CAM_ICRModelInq	8x	09	04	01	FF													pg: Shutter Position		
CAM_AutoICRModelInq	8x	09	04	51	FF													pg: Iris Position		
CAM_AutoICRThresholdInq	8x	09	04	21	FF													pg: Gain Position		
CAM_AutoICRAlarmReplyInq	8x	09	04	31	FF													pg: Gain Limit		
CAM_MemoryInq	8x	09	04	3F	FF													pg: ExpComp Mode On		
CAM_TitleDisplayModelInq	8x	09	04	74	FF													pg: ExpComp Mode Off		
CAM_PrivacyDisplayInq	8x	09	04	77	FF													pg: ExpComp Position		
CAM_PrivacyPanTiltInq	8x	09	04	79	FF													On		
CAM_PrivacyPTZInq	8x	09	04	7B	mm	FF												Off		
CAM_PrivacyMonitorInq	8x	09	04	6F	FF													pg: 0: mid, 1: low, 2: mid, 3: high		
CAM_MuteModelInq	8x	09	04	75	FF													Defog Off		
CAM_VersionInq	8x	09	00	02	FF													pg: Aperture Gain		
CAM_ColorGainInq	8x	09	04	49	FF													pg: 0-5 3D Noise Reduction		
CAM_ColorHueInq	8x	09	04	4F	FF													pg: 0-5 2D Noise Reduction		
CAM_TempInq	8x	09	04	68	FF													pg: 0-4 Gamma		
CAM_ImageStabilizerInq	8x	09	04	34	FF													Mirror Mode On		
CAM_AutoTempAlarmReplyInq	8x	09	04	68	FF													Mirror Mode Off		

4.8 VISCA Command Setting Values

Exposure control (1/2)

	Data	60/30 mode	50/25 mode
Shutter Speed	15h	1/10000	1/10000
	14h	1/6000	1/6000
	13h	1/4000	1/4000
	12h	1/3000	1/3000
	11h	1/2000	1/2000
	10h	1/1500	1/1500
	0Fh	1/1000	1/1000
	0Eh	1/725	1/725
	0Dh	1/500	1/500
	0Ch	1/350	1/350
	0Bh	1/250	1/250
	0Ah	1/180	1/180
	09h	1/120	1/120
	08h	1/100	1/100
	07h	1/90	1/75
	06h	1/60	1/50
	05h	1/30	1/25
	04h	1/15	1/12
	03h	1/8	1/6
	02h	1/4	1/3
01h	1/2	1/2	
00h	1/1	1/1	

Iris	11h	F1.8
	10h	F2
	0Fh	F2.4
	0Eh	F2.8
	0Dh	F3.4
	0Ch	F4
	0Bh	F4.8
	0Ah	F5.6
	09h	F6.8
	08h	F8
	07h	F9.6
	06h	F11
	05h	F14
	04h	F16
	03h	F22
00h	CLOSE	

	Data	Setting
Gain	1Ch	+54 dB
	1Bh	+52 dB
	1Ah	+50 dB
	19h	+48 dB
	18h	+46 dB
	17h	+44 dB
	16h	+42 dB
	15h	+40 dB
	14h	+38 dB
	13h	+36 dB
	12h	+34 dB
	11h	+32 dB
	10h	+30 dB
	0Fh	+28 dB
	0Eh	+26 dB
	0Dh	+24 dB
	0Ch	+22 dB
	0Bh	+20 dB
	0Ah	+18 dB
	09h	+16 dB
	08h	+14 dB
	07h	+12 dB
	06h	+10 dB
	05h	+8 dB
04h	+6 dB	
03h	+4 dB	
02h	+2 dB	
01h	0 dB	
00h	0 dB	

Gain Limit	1Ch	+54 dB
	1Bh	+52 dB
	1Ah	+50 dB
	19h	+48 dB
	18h	+46 dB
	17h	+44 dB
	16h	+42 dB
	15h	+40 dB
	14h	+38 dB
	13h	+36 dB
	12h	+34 dB
	11h	+32 dB
	10h	+30 dB
	0Fh	+28 dB
	0Eh	+26 dB
	0Dh	+24 dB
	0Ch	+22 dB
	0Bh	+20 dB
	0Ah	+18 dB
	09h	+16 dB
	08h	+14 dB
	07h	+12 dB
	06h	+10 dB
	05h	+8 dB
04h	+6 dB	

Exposure control (2/2)

	Data	IRIS	GAIN
Exposure Comp.	0Dh	+6	+12 dB
	0Ch	+5	+10 dB
	0Bh	+4	+8 dB
	0Ah	+3	+6 dB
	09h	+2	+4 dB
	08h	+1	+2 dB
	07h	0	0 dB
	06h	-1	-2 dB
	05h	-2	-4 dB
	04h	-3	-6 dB
	03h	-4	-8 dB
	02h	-5	-10 dB
	01h	-6	-12 dB

Zoom Ratio and Zoom Position (for reference)

Optical Zoom Ratio	Optical Zoom Position Data
x1	0000h
x2	18C3h
x3	2430h
x4	2B0Ch
x5	3049h
x6	3430h
x7	37CFh
x8	3AAAh
x9	3D86h
x10	4000h

Digital Zoom Ratio	Digital Zoom Position Data	Digital Zoom Max Setting Data
x1	4000h	00h
x2	6000h	80h
x4	7000h	C0h
x8	7800h	E0h
x12	7A80h	EAh
x16	7C00h	F0h

Lens control

Focus Position and Near Limit

Focus Position	1000h(Far End) to B000h(Near End)		
Focus Near Limit	1000h	Inf	
	2000h	4.7 m	
	3000h	2.3 m	
	4000h	1.5 m	
	5000h	1.1 m	
	6000h	0.9 m	
	7000h	0.8 m	
	8000h	25 cm	*initial setting
	9000h	9 cm	
	A000h	3.4 cm	
	B000h	1.0 cm	

* Above distance numbers are approximate values.

Temperature Reading Conversion Value (Reference Value)

Reading Value pq	Temperature Conversion Value (° C)
FBh	-8 to +2
00h	-3 to +3
0Ah	7 to 13
14h	17 to 23
1Eh	27 to 33
28h	37 to 43
32h	47 to 53
3Ch	57 to 63

White Balance Mode

Setting	Mode
00h	ATW1
01h	Indoor
02h	Outdoor
03h	One Push WB
04h	ATW2
05h	Manual

Gamma

Setting	Comment
0h	Standard
1h	Straight Gamma
2h	Low noise (narrow dynamic range)
3h	Wide Range

5. Specification

5.1 Specification

■ Camera	
Image sensor	1/2.8-type CMOS(Progressive Scan)
Effective number of pixels	Approx. 5.14M pixels
Image capture area	1920 x 1080 cropped from the effective pixels of the image sensor
Signal system (HD)	1080p/60, 1080p/59.94, 1080p/50, 1080p/30, 1080p/29.97, 1080p/25, 720p/60, 720p/59.94, 720p/50, 720p/30, 720p/29.97, 720p/25"
Signal system (SD)	NTSC/PAL
Minimum illumination	0.1 lx (1/30sec, F1.8, 50%, Color, typical) 0.025 lx (1/30sec, F1.8, 50%, B&W, typical)
Recommended illumination	100 lx to 100,000 lx
S/N ratio	More than 50 dB
Gain	Auto/Manual
Shutter speed	1/1 to 1/10,000 sec
Sync system	Internal
Exposure compensation	-12 dB to +12 dB (Total 13 steps)
Backlight compensation	On/Off
Gamma	4 gamma curves
Aperture control	16 steps
White balance	ATW1 (Narrow), ATW2 (Wide), One push, Manual (B, R), indoor, outdoor
AE (Auto exposure mode)	Auto, Manual, Priority mode (shutter/iris)
Lens (wide to tele)	10x optical zoom, F1.8 to 3.4
Zoom mode	Standard/Variable/Direct
Zoom movement speed (wide to tele)	1.4 sec(Focus Tracking On)
Digital Zoom	16x
Focusing system	Auto, Manual, One push, AF sensitivity
Horizontal viewing angle (wide to tele)	59.2° to 6.7°
Minimum Object distance	Visible: wide 10mm whole range 800mm 850nm: wide 10mm whole range 1200mm
■ Interface	
Video output (HD)	Digital: Y/Pb/Pr 4:2:2 (LVDS, HDMI)
Video output (SD)	CVBS (1Vp-p,75Ω)
Camera control interface	VISCA protocol *VISCA is a trademark of Sony Corporation.
■ Others	
Operating Voltage	DC 8 to 12V ±10%
Power Consumption	Approx. 2.5W (Approx. 4.4W during motor operation)
Operating Temperature	-5 to + 60 °C
Storage Temperature	-40 to + 60 °C
Operating Humidity	20% to 80% (No dew condensation)
Storage Humidity	20% to 90% (No dew condensation)
Dimension (W x H x D)	33 x 43 x 59mm
Weight	Approx. 70g

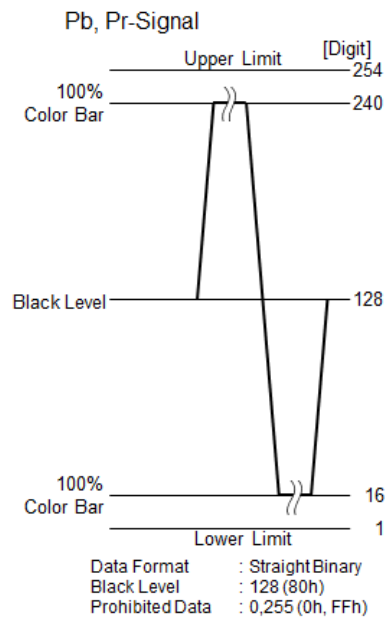
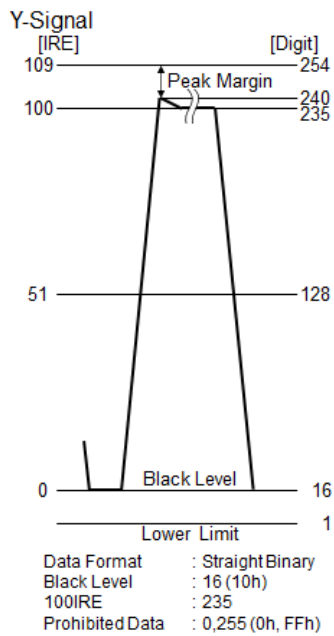

5.2 Dimension and Eclipse

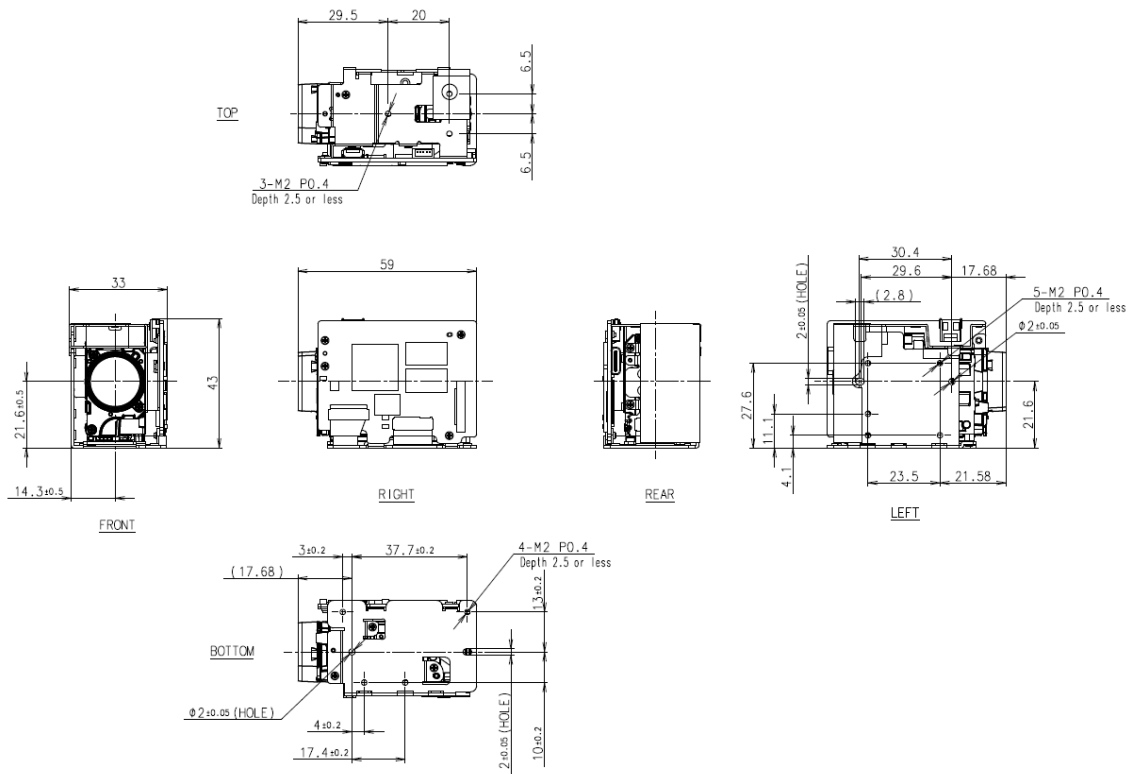

5.3 Interface

5.3.1 LVDS Interface Overview

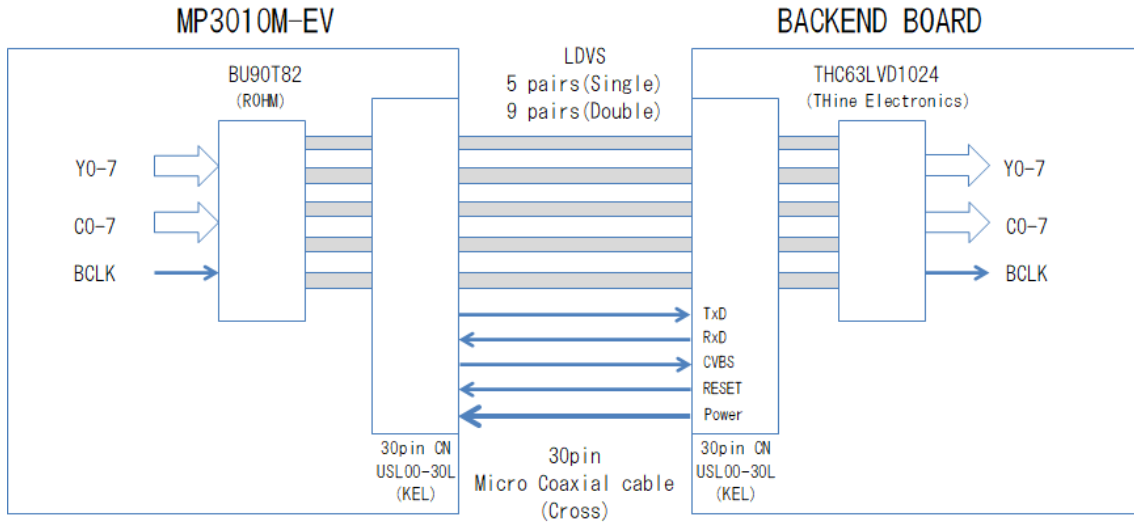

MP3010M-EV is using BU90T82 (LVDS Tx IC). A receiver (i.e., Backend Board in the above figure.) needs LVDS Rx IC such as THC63LVD1024, THC63LVD104C, BU90R102, etc.

5.3.2 LVDS Pin Assignment

LVDS signal 30pin Micro Coaxial cable pin assignment is as follows.

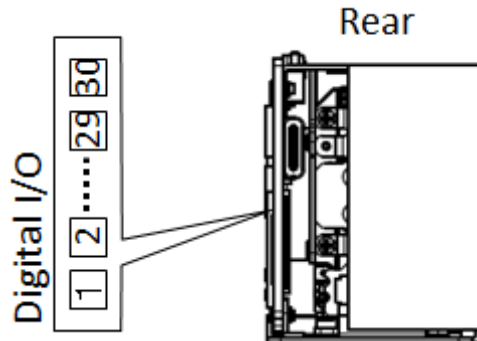

KEL Co. USL00-30L

No.	Pin Name	Description/Remarks
1	TXOUT3+	
2	TXOUT3-	
3	TXCLKOUT+	
4	TXCLKOUT-	
5	TXOUT2+	
6	TXOUT2-	
7	TXOUT1+	
8	TXOUT1-	
9	TXOUT0+	
10	TXOUT0-	
11	GND	
12	TxD HOST1	CMOS 3.3 V (Low: Max 0.55 V、High: Min 2.5 V)
13	RxD HOST1	CMOS 3.3 V (Low: Max 0.6 V、High: Min 2.4 V Max 5.0 V)
14	DC IN	8 ~ 12 V DC
15	DC IN	8 ~ 12 V DC
16	DC IN	8 ~ 12 V DC
17	DC IN	8 ~ 12 V DC
18	DC IN	8 ~ 12 V DC
19	GND	
20	GND	
21	TXOUT7+	Single out mode: Open
22	TXOUT7-	Single out mode: Open
23	TXOUT6+	Single out mode: Open
24	TXOUT6-	Single out mode: Open
25	CVBS	
26	RESET	Reset: Low (GND) , Normal: Open (3.3 V)
27	TXOUT5+	Single out mode: Open
28	TXOUT5-	Single out mode: Open
29	TXOUT4+	Single out mode: Open
30	TXOUT4-	Single out mode: Open

5.3.3 LVDS Pixel Data Format

Single Mode

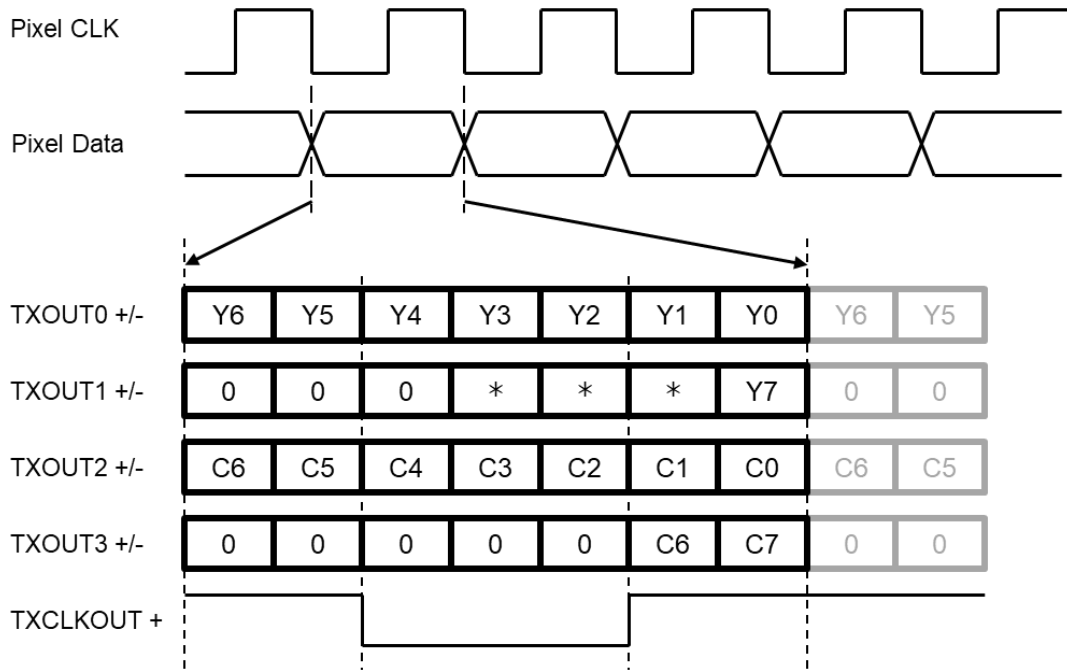

* Please ignore the value which can be "0" or "1".

Output Format	Pixel CLK [Hz]	TCLK+ [Hz]
1080p/59.94	148.5M/1.001	148.5M/1.001
1080p/29.97	74.25M/1.001	74.25M/1.001
720p/59.94	74.25M/1.001	74.25M/1.001
720p/29.97	74.25M/1.001	74.25M/1.001
1080p/60	148.5M	148.5M
1080p/50	148.5M	148.5M
1080p/30	74.25M	74.25M
1080p/25	74.25M	74.25M
720p/60	74.25M	74.25M
720p/50	74.25M	74.25M
720p/30	74.25M	74.25M
720p/25	74.25M	74.25M

Double Mode

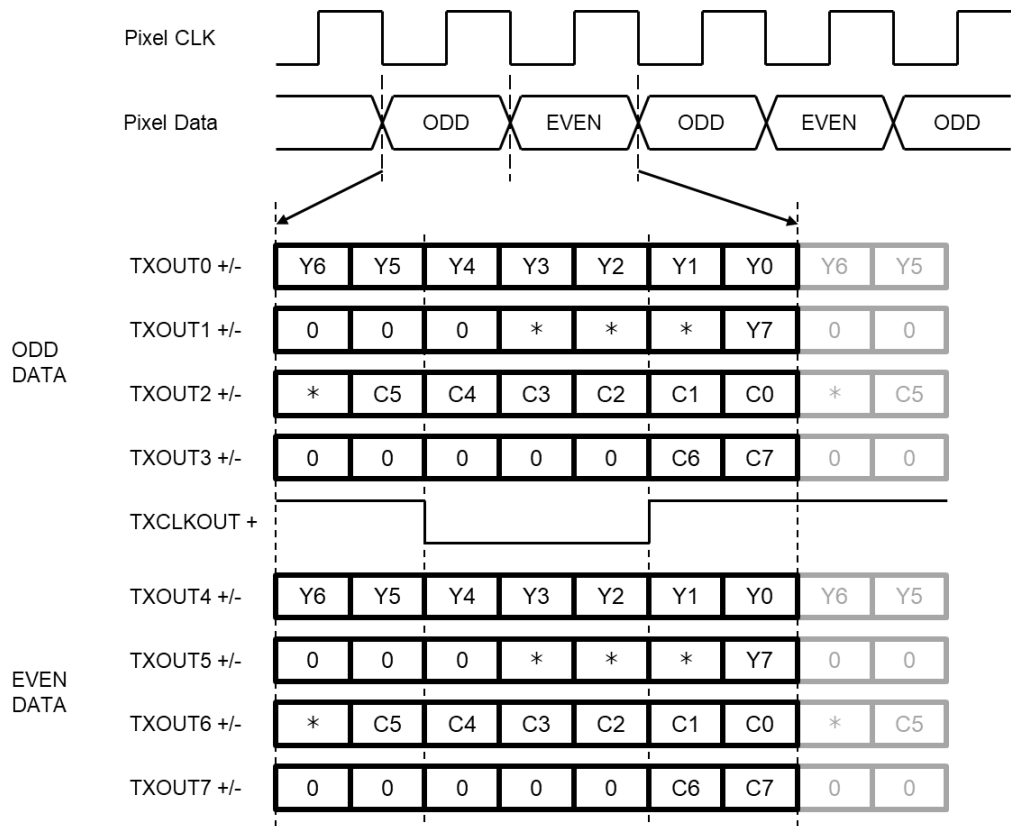

* Please ignore the value which can be "0" or "1" .

Output Format	Pixel CLK [Hz]	TCLK+ [Hz]
1080p/59.94	148.5M/1.001	74.25M/1.001
1080p/29.97	74.25M/1.001	37.125M/1.001
720p/59.94	74.25M/1.001	37.125M/1.001
720p/29.97	74.25M/1.001	37.125M/1.001
1080p/60	148.5M	74.25M
1080p/50	148.5M	74.25M
1080p/30	74.25M	37.125M
1080p/25	74.25M	37.125M
720p/60	74.25M	37.125M
720p/50	74.25M	37.125M
720p/30	74.25M	37.125M
720p/25	74.25M	74.25M

5.3.4 LVDS Rx Circuit Example

TAMRON is not liable for any damages to user's hardware incurred by the use of the circuit example shown below.

LVDS receiver circuit example① (Single output)

* Not compatible with 1080p/60, 59.94, 50

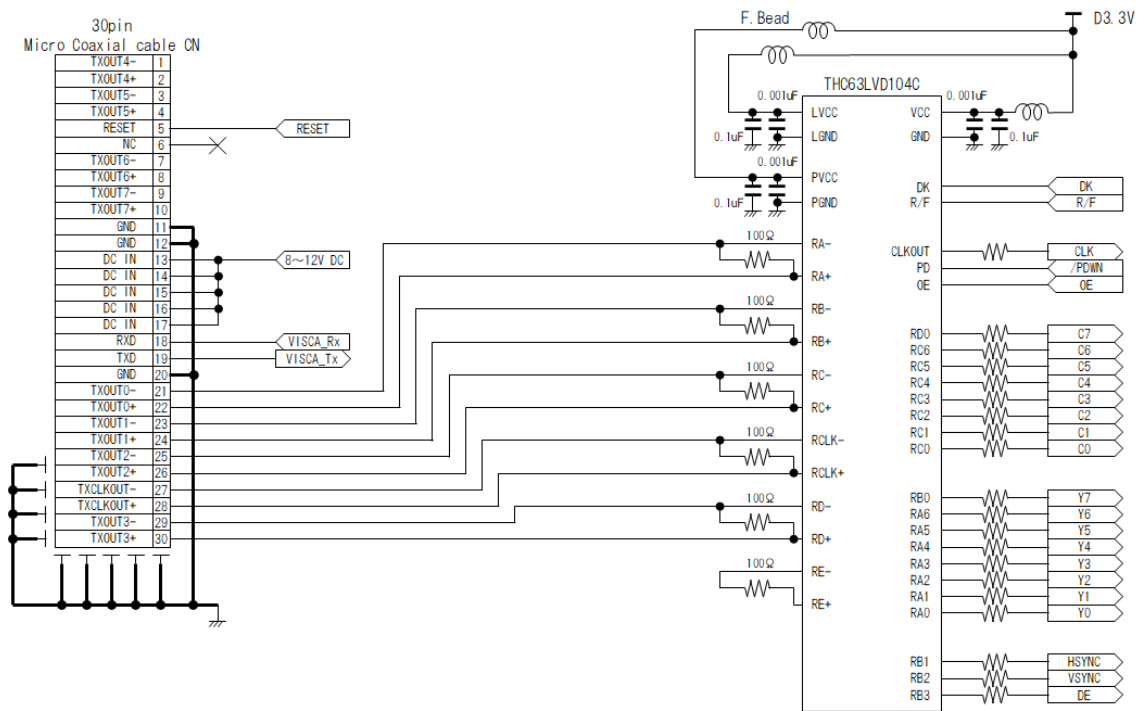

LVDS receiver IC (e.g., THC63LVD104C)

Pin assignment Single mode LVDS input - CMOS output

* Not compatible with 1080p/60, 59.94, 50

Pin No.	Description	Signal
1	GND_1	
2	TEST	
3	PD	
4	OE	
5	R/F	
6	RE6	
7	RE5	
8	RE4	
9	VCC_9	
10	RE3	
11	RE2	
12	RE1	
13	RE0	
14	RD6	
15	RD5	
16	GND_16	
17	RD4	
18	RD3	
19	RD2	
20	RD1	
21	RD0	C7
22	RC6	C6
23	VCC_23	
24	RC5	C5
25	RC4	C4
26	RC3	C3
27	RC2	C2
28	RC1	C1
29	RC0	C0
30	GND_30	
31	CLKOUT	CLK
32	RB6	

Pin No.	Description	Signal
33	RB5	
34	RB4	
35	RB3	DE
36	RB2	VSYNC
37	VCC_37	
38	RB1	HSYNC
39	RB0	Y7
40	RA6	Y6
41	RA5	Y5
42	RA4	Y4
43	RA3	Y3
44	GND_44	
45	RA2	Y2
46	RA1	Y1
47	RA0	Y0
48	VCC_48	
49	RA-	TXOUT0-
50	RA+	TXOUT0+
51	RB+	TXOUT1-
52	RB-	TXOUT1+
53	LVCC	
54	RC-	TXOUT2-
55	RC+	TXOUT2+
56	RCLK-	TXCLKOUT-
57	RCLK+	TXCLKOUT+
58	LGND	
59	RD-	TXOUT3-
60	RD+	TXOUT3+
61	RE-	
62	RE+	
63	PGND	
64	PVCC	

LVDS receiver circuit example② (Single output)

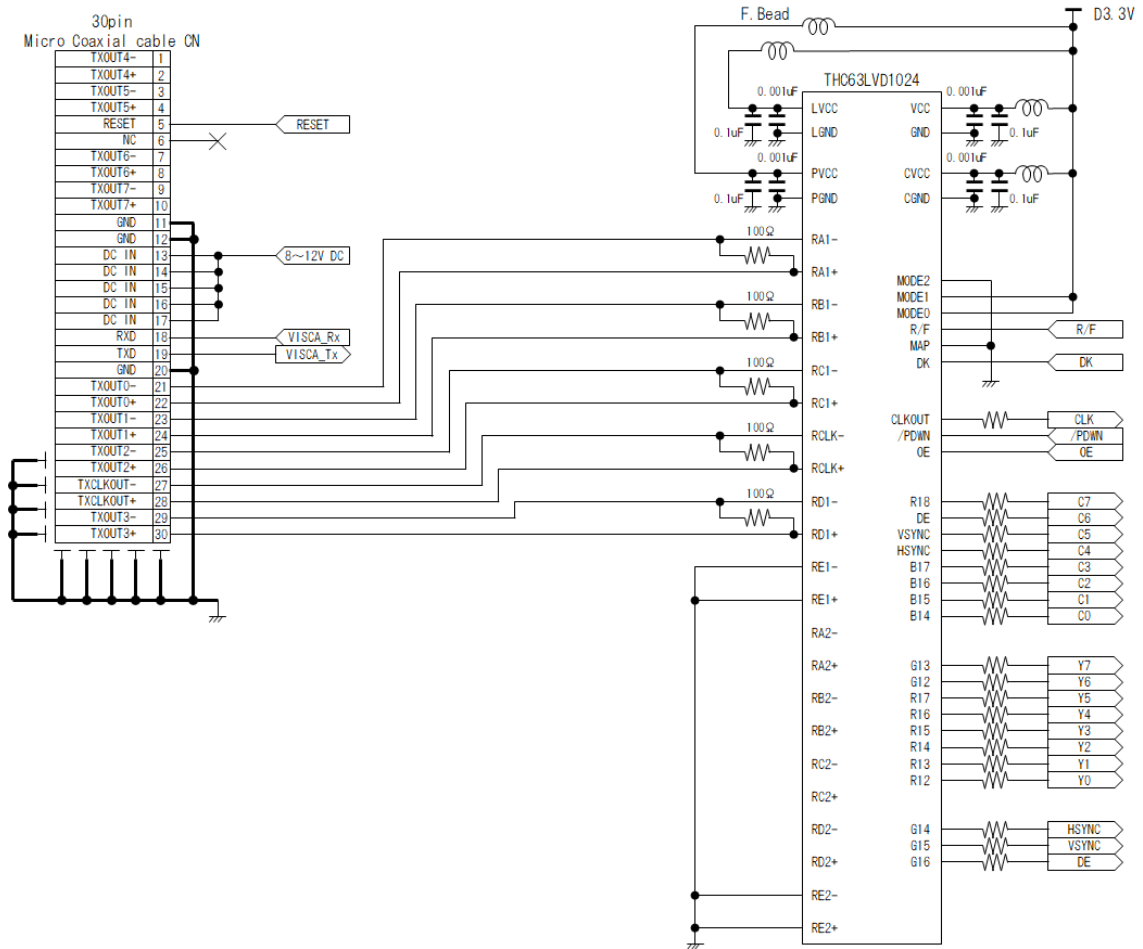

LVDS receiver IC (e.g., THC63LVD1024, BU90R102)

Pin assignment Single mode LVDS input - CMOS output

Pin No.	Description	Signal
1	PGND_1	
2	PVCC_2	
3	RESERVED	
4	PDWN	
5	MODE0	
6	MODE1	
7	DK	
8	R/F	
9	OE	
10	MODE2	
11	MAP	
12	VCC_12	
13	GND_13	
14	R20	
15	R21	
16	R22	
17	R23	
18	R24	
19	R25	
20	R26	
21	VCC_21	
22	GND_22	
23	R27	
24	R28	
25	R29	
26	G20	
27	G21	
28	VCC_28	
29	VCC_29	
30	GND_30	
31	G22	
32	G23	
33	G24	
34	G25	
35	G26	
36	G27	
37	G28	
38	VCC_38	
39	GND_39	
40	G29	
41	B20	
42	B21	
43	B22	
44	B23	
45	B24	
46	VCC_46	
47	GND_47	
48	B25	
49	B26	
50	B27	

Pin No.	Description	Signal
51	B28	
52	B29	
53	VCC_53	
54	GND_54	
55	CONT21	
56	CONT22	
57	VCC_57	
58	GND_58	
59	GND_59	
60	CLKOUT	CLK
61	CVCC	
62	CGND	
63	R10	
64	R11	
65	R12	Y0
66	R13	Y1
67	R14	Y2
68	R15	Y3
69	R16	Y4
70	VCC_70	
71	GND_71	
72	R17	Y5
73	R18	C7
74	R19	
75	G10	
76	G11	
77	G12	Y6
78	G13	Y7
79	G14	HSYNC
80	VCC_80	
81	GND_81	
82	G15	VSYNC
83	G16	DE
84	G17	
85	G18	
86	G19	
87	B10	
88	VCC_88	
89	GND_89	
90	B11	
91	B12	
92	B13	
93	B14	C0
94	B15	C1
95	B16	C2
96	B17	C3
97	VCC_97	
98	GND_98	
99	B18	
100	B19	

Pin No.	Description	Signal
101	HSYNC	C4
102	VSYNC	C5
103	DE	C6
104	CONT11	
105	CONT12	
106	VCC_106	
107	PVCC_107	
108	PGND_108	
109	LGND_109	
110	RA1-	TXOUT0-
111	RA1+	TXOUT0+
112	RB1-	TXOUT1-
113	RB1+	TXOUT1+
114	LVCC_114	
115	LGND_115	
116	RC1-	TXOUT2-
117	RC1+	TXOUT2+
118	RCLK-	TXCLKOUT-
119	RCLK+	TXCLKOUT+
120	LVCC_120	
121	LGND_121	
122	RD1-	TXOUT3-
123	RD1+	TXOUT3+
124	RE1-	
125	RE1+	
126	LVCC_126	
127	LGND_127	
128	RA2-	
129	RA2+	
130	RB2-	
131	RB2+	
132	LVCC_132	
133	LGND_133	
134	RC2-	
135	RC2+	
136	LGND_136	
137	LGND_137	
138	LVCC_138	
139	LVCC_139	
140	RD2-	
141	RD2+	
142	RE2-	
143	RE2+	
144	LGND_144	

LVDS receiver IC (e.g., THC63LVD1024, BU90R102)

Pin assignment Double mode LVDS input - CMOS output

Pin No.	Description	Signal
1	PGND_1	
2	PVCC_2	
3	RESERVED	
4	PDWN	
5	MODE0	
6	MODE1	
7	DK	
8	R/F	
9	OE	
10	MODE2	
11	MAP	
12	VCC_12	
13	GND_13	
14	R20	
15	R21	
16	R22	
17	R23	
18	R24	
19	R25	
20	R26	
21	VCC_21	
22	GND_22	
23	R27	
24	R28	
25	R29	
26	G20	
27	G21	
28	VCC_28	
29	VCC_29	
30	GND_30	
31	G22	
32	G23	
33	G24	
34	G25	
35	G26	
36	G27	
37	G28	
38	VCC_38	
39	GND_39	
40	G29	
41	B20	
42	B21	
43	B22	
44	B23	
45	B24	
46	VCC_46	
47	GND_47	
48	B25	
49	B26	
50	B27	

Pin No.	Description	Signal
51	B28	
52	B29	
53	VCC_53	
54	GND_54	
55	CONT21	
56	CONT22	
57	VCC_57	
58	GND_58	
59	GND_59	
60	CLKOUT	CLK
61	CVCC	
62	CGND	
63	R10	
64	R11	
65	R12	Y0
66	R13	Y1
67	R14	Y2
68	R15	Y3
69	R16	Y4
70	VCC_70	
71	GND_71	
72	R17	Y5
73	R18	C7
74	R19	C6
75	G10	
76	G11	
77	G12	Y6
78	G13	Y7
79	G14	HSYNC
80	VCC_80	
81	GND_81	
82	G15	VSYNC
83	G16	
84	G17	
85	G18	
86	G19	
87	B10	
88	VCC_88	
89	GND_89	
90	B11	
91	B12	
92	B13	
93	B14	C0
94	B15	C1
95	B16	C2
96	B17	C3
97	VCC_97	
98	GND_98	
99	B18	
100	B19	

Pin No.	Description	Signal
101	HSYNC	C4
102	VSYNC	C5
103	DE	DE
104	CONT11	
105	CONT12	
106	VCC_106	
107	PVCC_107	
108	PGND_108	
109	LGND_109	
110	RA1-	TXOUT0-
111	RA1+	TXOUT0+
112	RB1-	TXOUT1-
113	RB1+	TXOUT1+
114	LVCC_114	
115	LGND_115	
116	RC1-	TXOUT2-
117	RC1+	TXOUT2+
118	RCLK-	TXCLKOUT-
119	RCLK+	TXCLKOUT+
120	LVCC_120	
121	LGND_121	
122	RD1-	TXOUT3-
123	RD1+	TXOUT3+
124	RE1-	
125	RE1+	
126	LVCC_126	
127	LGND_127	
128	RA2-	TXOUT4-
129	RA2+	TXOUT4+
130	RB2-	TXOUT5-
131	RB2+	TXOUT5+
132	LVCC_132	
133	LGND_133	
134	RC2-	TXOUT6-
135	RC2+	TXOUT6+
136	LGND_136	
137	LGND_137	
138	LVCC_138	
139	LVCC_139	
140	RD2-	TXOUT7-
141	RD2+	TXOUT7+
142	RE2-	
143	RE2+	
144	LGND_144	

5.3.5 LVDS cable specification (reference)

Cable reference specifications (crossover)

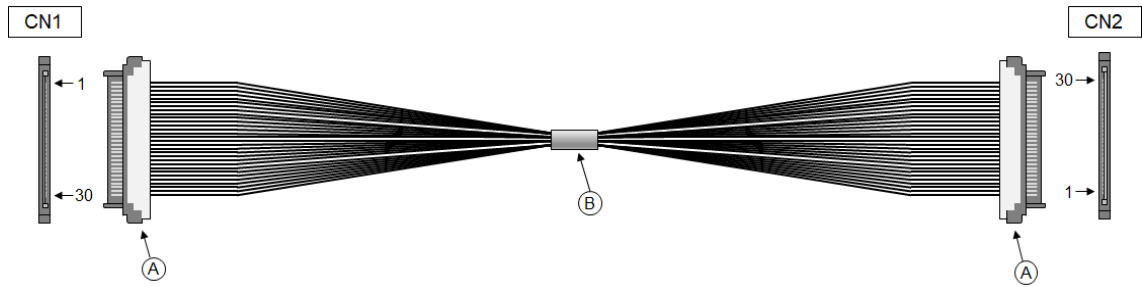

- Recommended connectors and cables

Cable: #42 Micro Coaxial cable

Connector[Ⓐ]: USL20-30S(KEL)

Binding tape[Ⓑ]

- Pin assignment

CN1	1	2	3	4	5	6	7	8	9	10	11	12	13	14	15	16	17	18	19	20	21	22	23	24	25	26	27	28	29	30
CN2	30	29	28	27	26	25	24	23	22	21	20	19	18	17	16	15	14	13	12	11	10	9	8	7	6	5	4	3	2	1

5.3.6 Synchronization Code

Synchronized codes

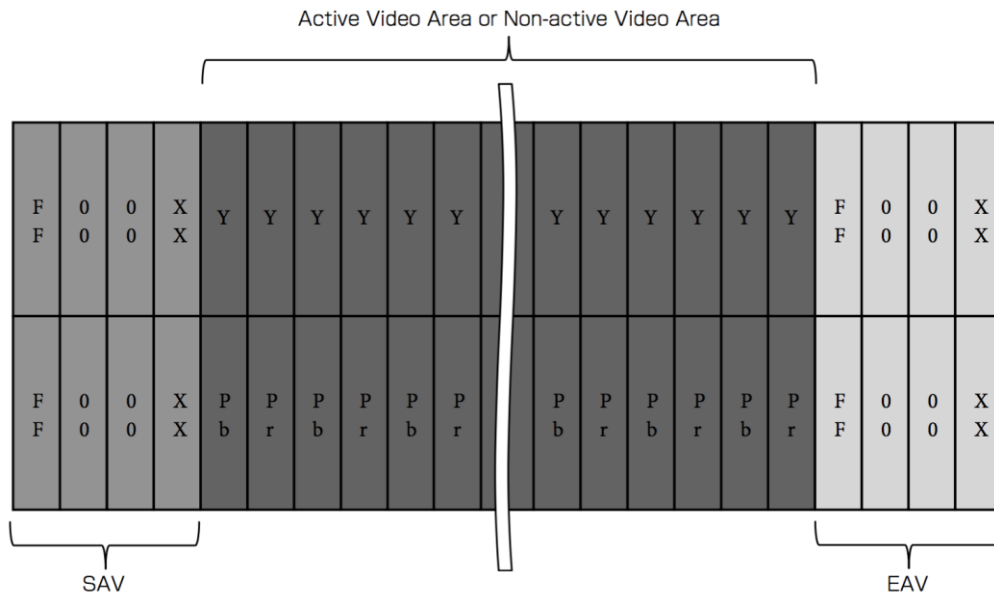

	XX for SAV	XX for EAV
Active Video Area	80h	9Dh
Non-active Video Area	ABh	B6h

Progressive system (Comparable to SMPTE 274M, 296M)

EAV	Blanking	SAV	
④	Blanking	②	Non-active Video Area
③	Blanking	①	Active Video Area
④	Blanking	②	Non-active Video Area

- ① SAV for Active Video Area
- ② SAV for Non-active Video Area
- ③ EAV for Active Video Area
- ④ EAV for Non-active Video Area

5.4 USB Interface

5.4.1 USB Interface Overview

USB Type-C connector on the rear side of the camera (see the figure below) is for the Firmware update function.

Note that double-sided insertion is not supported. If the cable is inserted back-side, the red LED next to the connector will light up.

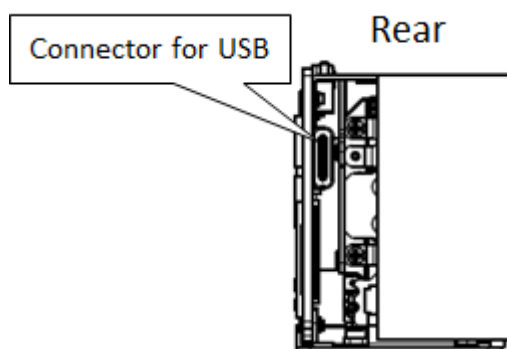

5.4.2 USB Pin Assignment

USB Type-C Connector pin assignment is as follows.

No.	Pin Name
A1	GND
A2	TXp1
A3	TXn1
A4	VBUS
A5	CC1 (Pull Down)
A6	Dp1 (Open)
A7	Dn1 (Open)
A8	SBU1 (Open)
A9	VBUS
A10	RXn2 (Open)
A11	RXp2 (Open)
A12	GND
B1	GND
B2	TXp2 (Open)
B3	TXn2 (Open)
B4	VBUS
B5	CC2 (Open)
B6	Dp2
B7	Dn2
B8	SBU2 (Open)
B9	VBUS
B10	RXn1
B11	RXp1
B12	GND

5.5 HDMI Interface

5.5.1 HDMI Interface Overview

HDMI signal is output from the micro HDMI Type D connector on the top of the camera (see the figure below).

Please use as a monitoring the video signal for adjusting the angle of view of the camera.

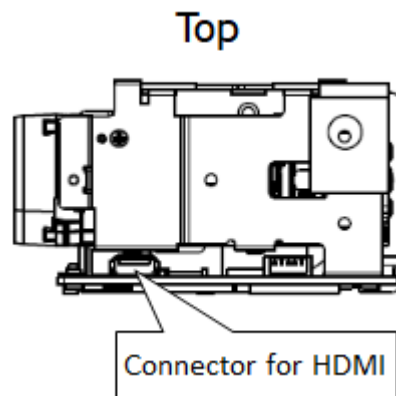

HDMI (High-Definition Multimedia Interface) is a video input/output interface standardized, this product is HDMI specification compliant.

This standard is mainly used to connect computers and display devices.

HDMI interface uses digital data as it is, so the signal does not change. (This product handles digital signals only)

The data format is “YCbCr Limited Range”.

If the operation mode of the display and the output setting of this product do not match, the video will not be displayed properly.

* The terms HDMI and HDMI High-Definition Multimedia Interface, and the HDMI Logo are trademarks or registered trademarks of HDMI Licensing Administrator, Inc. in the United States and other countries.

5.5.2 HDMI Pin Assignment

HDMI Connector is as follows.

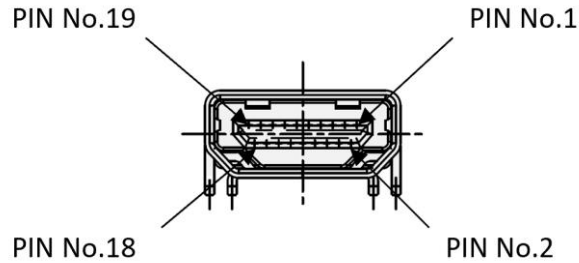

HDMI Type D Receptacle PIN assignment

No.	Pin Name
1	Hot Plug Detect
2	Utility (unconnected)
3	TMDS Data2+
4	TMDS Data2 Shield
5	TMDS Data2-
6	TMDS Data1+
7	TMDS Data1 Shield
8	TMDS Data1-
9	TMDS Data0+
10	TMDS Data0 Shield
11	TMDS Data0-
12	TMDS Clock+
13	TMDS Clock Shield
14	TMDS Clock-
15	CEC (unconnected)
16	DDC/CEC Ground
17	SCL
18	SDA
19	+5V Power